



Design And Implementation of Cascaded Multilevel Inverter Topology With Reduced Number Of Components

Doonaboyina Sandhya Rani¹, P Koteswara Rao²

M.Tech Student, Department of EEE, KIET, Kakinada, India.¹

Asst. Professor, Department of EEE, KIET, Kakinada, India.²

ABSTRACT—In this paper, using H-bridge topology a general cascade multilevel inverter for the implementation of 49th level inverter and a new algorithm in generating all voltage levels for a 49th level with less number of dc sources. Results in decreased complexity and economical. The comparison is done with the conventional topologies and confirmed by simulation results.

Index Terms— voltage source inverter, developed H-bridge, multilevel inverter, Cascaded multilevel inverter.

I. INTRODUCTION

With the progression in inverters, multilevel inverters have gotten more consideration since high-power and medium voltage appraisals gives advantage in of high power quality, bring down request sounds, and better electromagnetic impedance and so on. By fittingly masterminding the semi-conductor based switches the inverter will create a ventured voltage waveform. The principle structures of the multilevel inverters have been exhibited: "diode cinched multilevel inverter", "flying capacitor multilevel inverter," and "fell multilevel inverter". Multilevel inverters is made out of symmetric and lopsided gatherings in view of the dc voltage sources.

The fell multilevel inverter is made out of various single-stage H-connect inverters and is characterized into symmetric and unbalanced gatherings in view of the greatness of dc voltage sources. In the symmetric sorts, the extents of the dc voltage wellsprings of all H-scaffolds are equivalent while in the unbalanced sorts, the estimations of the dc voltage wellsprings of all H-extensions are distinctive. As of late, a few topologies with different control procedures have been exhibited for fell multilevel inverters [5]–[8]. In [4] and [9]–[15], diverse symmetric fell multilevel inverters have been displayed. The primary preferred standpoint of every one of these structures is the low assortment of dc voltage sources,

which is a standout amongst the most imperative elements in deciding the cost of the inverter. Then again, in light of the fact that some of them utilize a high number of bidirectional power switches, a high number of protected entryway bipolar transistors (IGBTs) are required, which is the principle hindrance of these topologies. A topsy-turvy topology has been exhibited in [16]. The principle impediment of this structure is identified with its bidirectional power switches, which cause an expansion in the quantity of IGBTs and the aggregate cost of the inverter. In [15], another topology with three calculations have been introduced, which lessen the quantity of required power switches however increment the assortment of dc voltage

sources. In [1], [4] and [17], and [18], a few calculations for deciding the extents of dc voltage hotspots for the ordinary fell multilevel inverter have been displayed. The real preferred standpoint of this topology and its calculations is identified with its capacity to produce an impressive number of yield voltage levels by utilizing a low number of dc voltage sources and power switches however the high assortment in the size of dc voltage sources is their most striking hindrance. In this paper, to expand the quantity of yield voltage levels and decrease the quantity of force switches, driver circuits, and the aggregate cost of the inverter, another topology of fell multilevel inverters is proposed. It is imperative to note that in the proposed topology, the unidirectional power switches are utilized. At that point, to decide the extent of the dc voltage sources, another calculation is proposed. Additionally, the proposed topology is contrasted and different topologies from various perspectives, for example, the quantity of IGBTs, number of dc voltage sources, the assortment of the estimations of the dc voltage sources, and the estimation of the blocking voltages per switch. At last, the execution of the proposed topology in producing all voltage levels through a 49 - level inverter is affirmed by MATLAB recreation.

II. PROPOSED TOPOLOGY

In Fig. 1, two new topologies are proposed for a seven-level inverter [19]. As appeared in Fig. 1, the proposed topologies are acquired by including two unidirectional power switches and one dc voltage source to the H-connect inverter structure. As it were, the proposed inverters are involved six unidirectional power switches ($S_a, S_b, S_{L,1}, S_{L,2}, S_{R,1},$ and $S_{R,2}$) and two dc voltage sources ($V_{L,1}$ and $V_{R,1}$). In this paper, these topologies are called developed H-bridge. As shown in Fig. 1, the simultaneous turn-on of $S_{L,1}$ and $S_{L,2}$ (or $S_{R,1}$ and $S_{R,2}$)

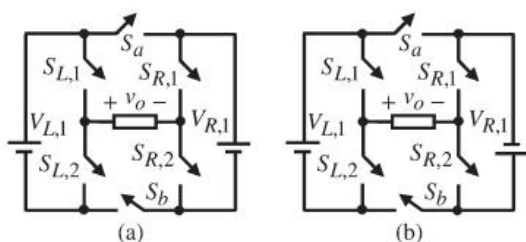

Fig. 1. Proposed seven-level inverters. (a) First proposed topology. (b) Second proposed topology.

No	$S_{L,1}$	$S_{L,2}$	$S_{R,1}$	$S_{R,2}$	S_a	S_b	Inverters (a) First proposed topology	(b) Second proposed topology
1	1	0	0	1	0	1	$V_{L,1} + V_{R,1}$	$V_{L,1} + V_{R,1}$
2	1	0	0	1	1	0	$V_{L,1}$	$V_{L,1}$
3	1	0	1	0	0	1	$V_{R,1}$	$V_{R,1}$
4	1	0	1	0	1	0	0	0
	0	1	0	1	0	1		
5	0	1	1	0	1	0	$-V_{L,1}$	$-V_{L,1}$
6	0	1	1	0	0	1	$-V_{R,1}$	$-V_{R,1}$
7	0	1	0	1	1	0	$-V_{L,1} - V_{R,1}$	$-V_{L,1} - V_{R,1}$

causes the voltage sources to short-circuit. Therefore, the simultaneous turn-on of the mentioned switches must be avoided. In addition, S_a and S_b should not turn on, simultaneously. The difference in the topologies illustrated in Fig. 1 is in the connection of the dc voltage sources polarity. Table I shows the output voltages of the proposed inverters for different states of the switches. In this table, 1 and 0 indicate the ON – and OFF – states of the switches, respectively. As it is obvious from Table I, if the values of the dc voltage sources are equal, the number of voltage levels decreases to three. Therefore, the values of dc voltage sources should be different to generate more voltage levels without increasing the number of switches and dc

voltage sources. Considering Table I, to generate all voltage levels (odd and even) in the proposed topology shown in Fig. 1(a), the magnitudes of $V_{L,1}$ and $V_{R,1}$ should be considered $3pu$ and $1pu$, respectively. Similarly, for the topology shown in Fig. 1(b), the magnitudes of $V_{L,1}$ and $V_{R,1}$ should be considered $2pu$ and $1pu$, respectively. Considering the aforementioned explanations, the total cost of the proposed topology in Fig. 1(b) is low because dc voltage sources with low magnitudes are needed. By developing the seven-level inverter shown in Fig. 1(b), the 31-level inverter shown in Fig. 2 can be proposed. This topology consists of ten unidirectional power switches and four dc voltage sources. According to Fig. 2, if the power switches of ($S_{L,1}, S_{L,2}$), ($S_{L,3}, S_{L,4}$), ($S_{R,1}, S_{R,2}$), and ($S_{R,3}, S_{R,4}$) turn on simultaneously, the dc voltage sources of $V_{L,1}, V_{L,2}, V_{R,1}$, and $V_{R,2}$ will be short-circuited, respectively. Therefore, the simultaneous turn-on of these switches should be avoided. In addition, S_a and S_b should not turn on simultaneously. It is important to note that the 127-level topology can be provided through the structure presented in Fig. 1(a), where the only difference will be in the polarity of the applied dc voltage sources. By developing the proposed 49th level inverter, a 49th-level inverter can be proposed as shown in Fig. 3. This topology

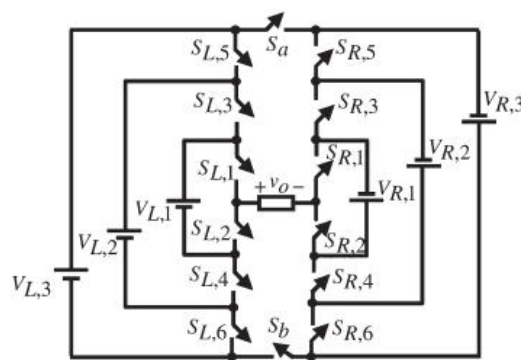

Fig. 3. Proposed 49-level inverter.

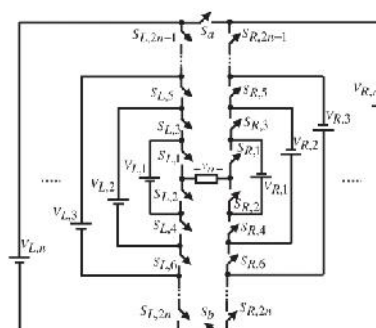

Fig. 4. Proposed general topology.

consists of 14 unidirectional power switches and 6 dc voltage sources. Similarly, by developing the proposed basic topology, a general topology, as shown in Fig. 4, can be proposed. The general topology consists of $2n$ dc voltage sources (n is the number of the dc voltage sources on each leg) and $4n + 2$ unidirectional power switches. In the proposed general topology, the number of output voltage levels (N_{step}), number of switches (N_{switch}), number of dc voltage sources (N_{source}), and the maximum magnitude of the generated voltage ($V_{o,max}$) are calculated as follows, respectively:

$$N_{step} = 2^{2n+1} - 1 \quad \text{----- (1)}$$

$$N_{switch} = 4n + 2 \quad \text{----- (2)}$$

$$N_{source} = 2n \quad \text{----- (3)}$$

$$V_{o,max} = V_{L,n} + V_{R,n} \quad \text{----- (4)}$$

The other important parameters of the total cost of a multilevel inverter for evaluation are the variety of the values of dc voltage sources and the value of the blocking voltage of the switches. As the variety of dc voltage sources and the value of the blocking voltage of the switches are low, the inverter's total cost decreases [20]. The number of variety of the values of dc voltage sources ($N_{variety}$) is given by

$$N_{variety} = 2n \quad \text{----- (5)}$$

The following pattern is utilized to calculate the maximum magnitude of the blocking voltage of the power switches. As shown in Fig. 1(b), the blocking voltage of $S_{R,1}$ and $S_{R,2}$ are calculated as follows:

$$V_{SR,1} = V_{SR,2} = V_{R,1} \quad \text{----- (6)}$$

Where $V_{SR,1}$ and $V_{SR,2}$ indicate the maximum blocking voltages of $S_{R,1}$ and $S_{R,2}$, respectively. The blocking voltage of $S_{L,1}$ and $S_{L,2}$ are as follows:

$$V_{SL,1} = V_{SL,2} = V_{L,1} \quad \text{----- (7)}$$

Where $V_{SL,1}$ and $V_{SL,2}$ indicate the maximum blocking voltages of $S_{L,1}$ and $S_{L,2}$, respectively. Therefore, the maximum blocking voltage of all switches in the proposed seven-level inverter ($V_{block,1}$) is calculated as follows:

$$\begin{aligned} V_{block,1} &= V_{SR,1} + V_{SR,2} + V_{SL,1} + V_{SL,2} + V_{Sa} + V_{Sa} \\ &= 4(V_{R,1} + V_{L,1}) \end{aligned} \quad \text{----- (8)}$$

Considering Fig. 2, the maximum blocking voltage of the switches is as follows:

$$V_{SR,1} = V_{SR,2} = V_{R,1} \quad \text{----- (9)}$$

$$V_{SR,3} = V_{SR,4} = V_{R,2} - V_{R,1} \quad \text{----- (10)}$$

$$V_{SL,1} = V_{SL,2} = V_{L,1} \quad \text{----- (11)}$$

$$V_{SL,3} = V_{SL,4} = V_{L,2} - V_{L,1} \quad \text{----- (12)}$$

$$V_{Sa} = V_{Sb} = V_{R,2} + V_{L,2} \quad \text{----- (13)}$$

Therefore, the maximum blocking voltage of all switches of the proposed 31-level inverter ($V_{block,2}$) is as follows:

$$\begin{aligned} V_{block,2} &= V_{SR,1} + V_{SR,2} + V_{SR,3} + V_{SR,4} + V_{SL,1} + V_{SL,2} \\ &\quad + V_{SL,3} + V_{SL,4} + V_{Sa} + V_{Sb} \\ &= 4(V_{R,2} + V_{L,2}) \end{aligned} \quad \text{----- (14)}$$

Similarly, the maximum blocking voltage of all switches of the 49-level inverter is calculated as follows:

$$V_{block,3} = 4(V_{R,3} + V_{L,3}) \quad \text{----- (15)}$$

Finally, the maximum blocking voltage of all the switches of the general topology ($V_{block,n}$) is calculated as follows:

$$V_{block,n} = 4(V_{R,n} + V_{L,n}) \quad \text{----- (16)}$$

III. PROPOSED ALGORITHM TO DETERMINE THE MAGNITUDES OF DC VOLTAGE SOURCES

In this paper, the following algorithm is applied to determine the magnitude of dc voltage sources. It is important to note that all voltage levels (even and odd) can be generated.

A. Proposed 49-Level Inverter

The magnitudes of the dc voltage sources of the proposed 127-level inverter are calculated as follows:

$$V_{L,1} = V_{dc} \quad \text{----- (17)}$$

$$V_{R,1} = 2V_{dc} \quad \text{----- (18)}$$

$$V_{L,2} = 5V_{dc} \quad \text{----- (19)}$$

$$V_{R,2} = 10V_{dc} \quad \text{----- (20)}$$

$$V_{L,3} = 25V_{dc} \quad \text{----- (21)}$$

$$V_{R,3} = 50V_{dc} \quad \text{----- (22)}$$

By using this algorithm, the inverter can generate all negative and positive voltage levels from 0 to 63 V_{dc} with steps of V_{dc}

D. Proposed General Multilevel Inverter

The magnitudes of the dc voltage sources of the proposed general multilevel inverter can be obtained as follows:

$$V_{Lj} = 5^{j-1}V_{dc} \text{ for } j = 1, 2, 3, \dots, n \quad (23)$$

$$V_{Rj} = 2 \times 5^{j-1}V_{dc} \text{ for } j = 1, 2, 3, \dots, n \quad (24)$$

Considering (4) and (16), the values of $V_{o,max}$ and $V_{block,n}$ of the proposed general multilevel inverter are as follows, respectively:

$$V_{o,max} = V_{L,n} + V_{R,n} = 3 \times 5^{n-1}V_{dc} \quad (25)$$

$$V_{block,n} = 4(V_{L,n} + V_{R,n}) = 12(5^{n-1})V_{dc} \quad (26)$$

IV. CALCULATION OF LOSSES

Mainly, two kinds of losses (i.e., conduction and switching losses) are associated with the switches. Since the switches include IGBTs and diodes, the conduction losses of an IGBT ($p_{c,IGBT}(t)$) and a diode ($p_{c,D}(t)$) are calculated as follows, respectively [7], [22]:

$$p_{c,IGBT}(t) = [V_{IGBT} + R_{IGBT}i^\beta(t)]i(t) \quad (27)$$

$$p_{c,D}(t) = [V_{IGBT} + R_{IGBT}i^\beta(t)]i(t) \quad (28)$$

Where V_{IGBT} and V_D are the forward voltage drops of the IGBT and diode, respectively. R_{IGBT} and R_D are the equivalent resistances of the IGBT and diode, respectively, and β is a constant related to the specification of the IGBT. Considering that at instant t , there are N_{IGBT} transistors and N_D diodes in the current path, the average value of the conduction power loss (P_c) of the multilevel inverter can be written as follows:

$$P_c = \frac{1}{2} \int_0^{2\pi} [N_{IGBT}(t)p_{c,T}(t) + N_D(t)p_{c,D}(t)] dt \quad (29)$$

The switching losses are calculated based on the energy loss calculation. The switching losses occur during the turn-off and turn-on periods. For simplicity, the linear variations of the voltage and current of the switches in the switching period are considered. Based on this assumption, the following relations can be written [7], [22]:

$$E_{off,k} = \int_0^{t_{off}} v(t)i(t)dt = \frac{1}{6}V_{sw,k}It_{off} \quad (28)$$

$$E_{on,k} = \int_0^{t_{on}} v(t)i(t)dt = \frac{1}{6}V_{sw,k}I't_{on} \quad (29)$$

Where $E_{off,k}$ and $E_{on,k}$ are the turn-off and turn-on losses of the switch k , respectively. t_{off} and t_{on} are the turn-off and turn-on times of the switch, respectively, I is the current through the switch before turning off, I' is the current through the switch after turning on, and $V_{sw,k}$ is the OFF-state voltage on the switch. The switching power loss (P_{sw}) is equal to the sum of all turn-on and turn-off energy losses in a fundamental cycle of the output voltage. This can be written as follows [7], [22]:

$$P_{sw} = f \sum_{k=1}^{N_{switch}} \left(\sum_{i=1}^{N_{on,k}} E_{on,ki} + \sum_{i=1}^{N_{off,k}} E_{off,ki} \right) \quad (30)$$

Where f is the fundamental frequency and $N_{on,k}$ and $N_{off,k}$ are the numbers of turn-on and turn-off of the switch k during a fundamental cycle. Also, $E_{on,ki}$ is the energy loss of the switch k during the i th turn-on and $E_{off,ki}$ is the energy loss of the switch k during the i th turn-off. The total loss (P_{loss}) of the multilevel converter is the sum of the conduction and switching losses as follows:

$$P_{loss} = P_c + P_{sw} \quad (31)$$

Finally, the efficiency (η) of the inverter is calculated as follows:

$$\eta = \frac{P_{out}}{P_{in}} = \frac{P_{out}}{P_{out} + P_{loss}} \quad (32)$$

Where P_{out} and P_{in} denote the output and input powers of the inverter.

V. COMPARING THE PROPOSED GENERAL TOPOLOGY WITH THE CONVENTIONAL TOPOLOGIES

In order to clarify the advantages and disadvantage of the proposed topology, it should be compared with the different kinds of topologies presented in literature. In [4], the conventional cascaded multilevel inverter with two different algorithms has been presented. These algorithms are known as the symmetric cascaded multilevel inverters and the asymmetric ones with the binary method for determining the magnitude of dc voltage sources. In the comparison, the conventional symmetric cascaded multilevel inverter is indicated by

R_1 and the conventional binary asymmetric cascaded multilevel inverter is shown by R_2 . Three other algorithms have been presented for this topology in [1], [17], and [18], which are indicated by R_3 – R_5 , respectively. Moreover, another topology with three different algorithms for determining the value of dc voltage sources has been introduced in [15], which are shown by R_{13} – R_{15} in this comparison. In [9]–[12], four different structures for the cascaded multilevel inverter have been presented, and in this paper, they are indicated by R_6 – R_7 and R_{11} – R_{12} . It is important to note that the power switches in the aforementioned topologies are unidirectional. In addition, other topologies based on bidirectional switches have been presented in [13] and [14]. In [14], three different algorithms have been recommended, which are denoted as R_8 – R_{10} , and the presented topology in [13] is indicated by R_{16} in this comparison. Fig. 5 shows all of the aforementioned structures. Fig. 6 compares the number of IGBTs of the proposed general topology with the aforementioned cascaded multilevel inverters. It is obvious that the proposed inverter requires a lesser number of IGBTs in comparison with the other mentioned topologies to generate particular levels. Fig. 7 compares the number of dc voltage sources of the proposed inverter with the aforementioned cascaded multilevel inverter. As shown in Fig. 7, the proposed inverter has better performance in comparison with the other presented topologies except the topology presented in R_3 . However, the magnitude of the dc voltage sources in R_3 is a little more than that of the proposed topology.

Fig. 8 compares the variety of magnitudes of the dc voltage sources of the proposed inverter with that of the aforementioned cascaded multilevel inverter. Obviously, the proposed inverter uses a wider variety of magnitudes of the dc voltage sources in comparison with those of all the aforementioned topologies. This feature is the most important disadvantage of the proposed topology because the variety of the values of dc voltage sources is as one of the remarkable factors in determining the cost of the inverter. However, this feature in the proposed topology is similar to the presented topologies of R_2

and R_{14} . Fig. 9 compares the magnitude of the blocking voltage of the switches of the proposed inverter with that of the aforementioned cascaded multilevel inverter. This figure shows the reduction of the magnitude of the blocking voltage of the proposed inverter in comparison with those of all the aforementioned multilevel inverters.

VI. SIMULATION RESULTS

In order to verify the correct performance of the proposed multilevel inverter in generating all output voltage levels (even and odd), a 49-level inverter based on the topology shown in Fig. 2 has been used for the simulation. Table II shows the switching states of the 49-level inverter.

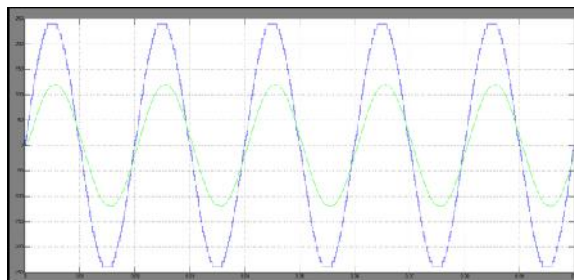
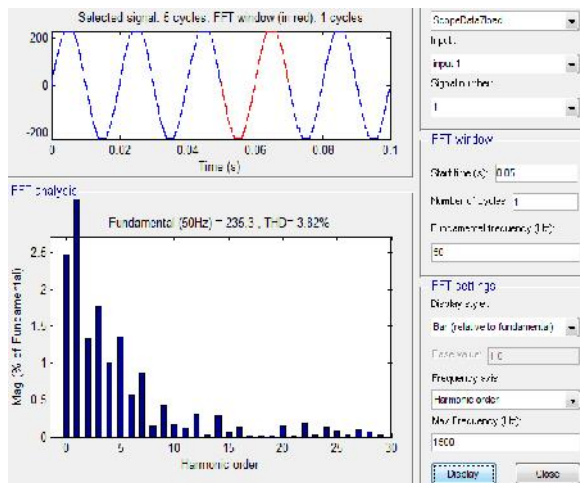

Fig. 11 49 level voltage and current

The simulation is done by using MATLAB software, and the practical prototype is made in the experimental environment. Fig. 10 shows the experimental setup. It is important to note that the IGBTs used in the prototype are HGTP10N40CID (with an internal anti-parallel diode) with the voltage and current ranges of 400 V and 10 A, respectively. The 89C52 microcontroller by ATMEL Company has been used to generate all switching patterns. In all processes of the simulation and experiment, the load is assumed as R–L with $R=45$ and $L=55$ mH. Moreover, the magnitude of $V_{L,1}$ is considered 15 V, so based on (29) and (30), the magnitudes of the other dc voltage sources will be 30, 75, and 150 V, which are related to $V_{R,1}$, $V_{L,2}$, and $V_{R,2}$, respectively. According to (31), the maximum output voltage of this inverter will be 225 V. In this paper, the fundamental frequency switching control method has been used [21]. In this method, the sinusoidal reference voltage is compared with the available dc voltage levels and the level that is nearest to the reference voltage is chosen [22]. The main advantage of this control method is related to its low switching frequency, which leads to reduction of switching losses. The simulated output voltage and current waveforms are shown in Fig. 11. As Fig. 11(a) shows, the proposed topology is able to generate 31 levels (15 positive levels, 15 negative levels, and 1 zero level) with the maximum voltage of 225 V. Comparing the output voltage and current waveforms indicates that the output current waveform is more similar to the ideal sinusoidal waveform than the output voltage because the R–L load acts as a low-pass filter. In addition, there is a phase difference between the output voltage and current waveforms, which is caused by the inductive feature of the load. The total harmonic distortions of the output voltage and current are equal to 0.94% and 0.19%, respectively. Fig. 12(a) and (b) shows the

harmonic spectrum of the output voltage and current, respectively. The figure shows that the magnitudes of harmonics of both voltage and current waveforms are low. However, the harmonics of the current waveform are lower than the voltage



(a) Harmonic spectrum of output voltage of 31 level inverter

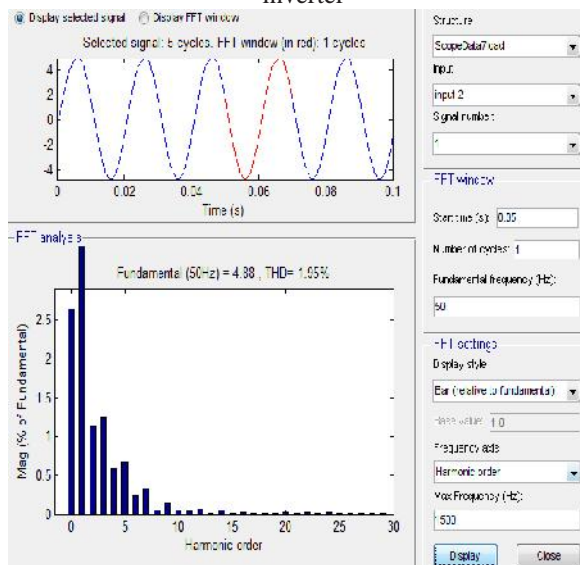

(b)

Fig. 12. Harmonic spectrum of (a) output voltage of 49 level inverter

considered nonlinear. In the test condition, the measured input and output powers are about 1203 and 1112 W, respectively. Therefore, the efficiency is about 92.4%. Based on the loss calculations given before, the power loss is about 86 W. Therefore, the calculated loss has a good accordance with the measured efficiency. As mentioned before, the power switches in the proposed topology are unidirectional from the voltage viewpoint.

In order to prove this issue, the voltages on the switches of a single leg of the inverter (*i.e.*, $S_{L,1}$, $S_{L,2}$, $S_{L,3}$, $S_{L,4}$, and S_a) are shown in Fig. 13. As can be seen, the maximum blocking voltage by switches $S_{L,1}$, $S_{L,2}$, $S_{L,3}$, $S_{L,4}$, and S_a are equal to 15, 15, 60, 60, and 225 V, respectively. Obviously, the voltage values are zero or equal to the positive ones, which is well in accordance to the unidirectional feature of the switches from the voltage view point. Considering the magnitude of the blocking voltage of the switches, the relations associated to the maximum voltage drop of the switches are well confirmed. Fig. 14 shows the experimental results of the implemented inverter. It is important to note that there is a good agreement between the experimental and simulation results.

VII. CONCLUSION

In this paper, two basic topologies have been proposed for multilevel inverters to generate seven voltage levels at the output. The basic topologies can be developed to any number of levels at the output where the 49-level and general topologies are consequently presented. In addition, a new algorithm to determine the magnitude of the dc voltage sources has been proposed. The proposed general topology was compared with the different kinds of presented topologies in literature from different points of view. According to the comparison results, the proposed topology requires a lesser number of IGBTs, power diodes, driver circuits, and dc voltage sources. Moreover, the magnitude of the blocking voltage of the switches is lower

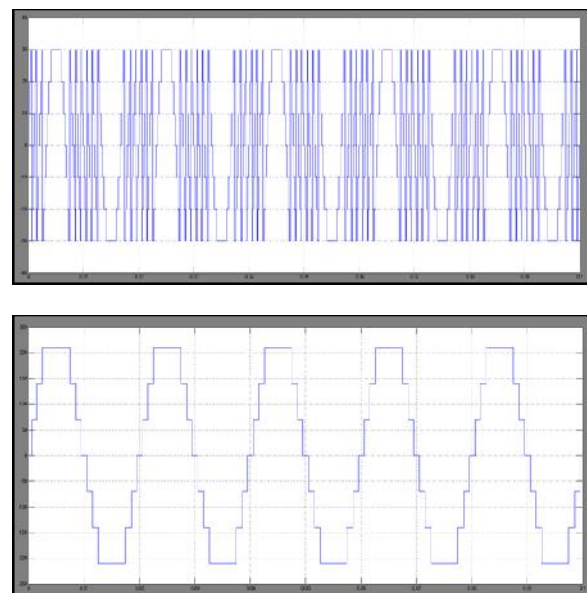

Fig. 13. Voltages of switches (a) $S_{L,1}$, (b) $S_{L,2}$

than that of conventional topologies. However, the proposed topology has a higher number of variety of dc

voltage sources in comparison with the others. The performance accuracy of the proposed topology was verified through the MATLAB simulation and the experimental results of a 49-level inverter.

REFERENCES

- [1] Ebrahim Babaei, *Member, IEEE*, Somayeh Alilu, and Sara Laali, *Student Member, IEEE* "A New General Topology for Cascaded Multilevel Inverters With Reduced Number of Components Based on Developed H-Bridge" *IEEE TRANSACTIONS ON INDUSTRIAL ELECTRONICS*, VOL. 61, NO. 8, AUGUST 2014
- [2] E. Babaei and S. H. Hosseini, "Charge balance control methods for asymmetrical cascade multilevel converters," in *Proc. ICEMS*, Seoul, Korea, 2007, pp. 74–79.
- [3] K. Wang, Y. Li, Z. Zheng, and L. Xu, "Voltage balancing and fluctuationsuppression methods of floating capacitors in a new modular multilevel converter," *IEEE Trans. Ind. Electron.*, vol. 60, no. 5, pp. 1943–1954, May 2013.
- [4] J. Ebrahimi, E. Babaei, and G. B. Gharehpetian, "A new topology of cascaded multilevel converters with reduced number of components for high-voltage applications," *IEEE Trans. Power Electron.*, vol. 26, no. 11, pp. 3109–3118, Nov. 2011.
- [5] M. Manjrekar and T. A. Lipo, "A hybrid multilevel inverter topology for drive application," in *Proc. APEC*, 1998, pp. 523–529.
- [6] M. Narimani and G. Moschopoulos, "A novel single-stage multilevel type full-bridge converter," *IEEE Trans. Ind. Electron.*, vol. 60, no. 1, pp. 31–42, Jan. 2013.
- [7] N. Abd Rahim, M. F. Mohamad Elias, and W. P. Hew, "Transistor-clamped H-bridge based cascaded multilevel inverter with new method of capacitor voltage balancing," *IEEE Trans. Ind. Electron.*, vol. 60, no. 8, pp. 2943–2956, Aug. 2013.
- [8] S. R. Pulikanti, G. Konstantinou, and V. G. Agelidis, "Hybrid seven-level cascaded active neutral-point-clamped-based multilevel converter under SHE-PWM," *IEEE Trans. Ind. Electron.*, vol. 60, no. 11, pp. 4794–4804, Nov. 2013.
- [9] Y. Hinago and H. Koizumi, "A single-phase multilevel inverter using switched series/parallel dc voltage sources," *IEEE Trans. Ind. Electron.*, vol. 57, no. 8, pp. 2643–2650, Aug. 2010.
- [10] G. Waltrich and I. Barbi, "Three-phase cascaded multilevel inverter using power cells with two inverter legs in series," *IEEE Trans. Ind. Appl.*, vol. 57, no. 8, pp. 2605–2612, Aug. 2010.
- [11] W. K. Choi and F. S. Kang, "H-bridge based multilevel inverter using PWM switching function," in *Proc. INTELEC*, 2009, pp. 1–5.
- [12] E. Babaei, M. Farhadi Kangarlu, and F. Najaty Mazgar, "Symmetric and asymmetric multilevel inverter topologies with reduced switching devices," *Elect. Power Syst. Res.*, vol. 86, pp. 122–130, May 2012.
- [13] J. Ebrahimi, E. Babaei, and G. B. Gharehpetian, "A new multilevel converter topology with reduced number of power electronic components," *IEEE Trans. Ind. Electron.*, vol. 59, no. 2, pp. 655–667, Feb. 2012.
- [14] E. Babaei, S. H. Hosseini, G. B. Gharehpetian, M. Tarafdar Haque, and M. Sabahi, "Reduction of DC voltage sources and switches in asymmetrical multilevel converters using a novel topology," *Elect. Power Syst. Res.*, vol. 77, no. 8, pp. 1073–1085, Jun. 2007.
- [15] E. Babaei and S. H. Hosseini, "New cascaded multilevel inverter topology with minimum number of switches," *Energy Convers. Manage.*, vol. 50, no. 11, pp. 2761–2767, Nov. 2009.
- [16] S. Mekhilef and M. N. Kadir, "Voltage control of three-stage hybrid multilevel inverter using vector transformation," *IEEE Trans. Power Electron.*, vol. 25, no. 10, pp. 2599–2606, Oct. 2010.
- [17] A. Rufer, M. Veenstra, and K. Gopakumar, "Asymmetric multilevel converter for high resolution voltage phasor generation," presented at the *Proc. EPE*, Lausanne, Switzerland, 1999.
- [18] S. Laali, K. Abbaszades, and H. Lesani, "A new algorithm to determine the magnitudes of dc voltage sources in asymmetrical cascaded multilevel converters capable of using charge balance control methods," in *Proc. ICEMS*, Incheon, Korea, 2010, pp.