



## International Journal of Science Engineering and Advance Technology

### Design and Analysis of a Propeller Shaft in CAE tool and ANSYS

Gara Bharat Kumar <sup>#1</sup>, M Manoj <sup>#2</sup>, P.Satish Reddy <sup>#3</sup>

Scholar of Master of Technology, Asst Professor, Assoc Professor

Dept of Mechanical Engineering, Prasiddha College of Engg & Tech, Anathavaram  
gbharkumar24@gmail.com, mattamanoj13@gmail.com, satish2436@gmail.com

#### Abstract:

A Propeller Shaft is a device on which a propeller is attached to and transfers the power from the engine to the propeller. In the design of automobiles, the industry is exploiting in order to obtain reduction of weight without significant decrease in vehicle quality and reliability. This is due to the fact that the reduction of weight of a vehicle directly impacts its fuel consumption. Particularly in city driving, the reduction of weight is almost directly proportional to fuel consumption of the vehicle. A Propeller Shaft is a longitudinal drive shaft used in vehicles where the engine is suited at the opposite end of the vehicle to the drive wheels. A propeller shaft is an assembly of one or more tubular shaft connected by universal, constant velocity or flexible joints. Thus, in this project work the propeller shaft of a vehicle was chosen and analyzed by replacing it with different materials

**Keywords:** Propeller Shaft, catiav5, ANSYS, Steel-Reference Material, Boron, Kevlar, Aluminum, Glass, Carbon, analysis

#### I. INTRODUCTION

In the process of designing a vehicle, one of the most important objectives is the conservation of energy and the most effective way to obtain this goal is the reduction of weight of the vehicle. There is almost a direct proportionality between the weight of the vehicle and its fuel consumption, particularly in city driving. The automotive industry is exploiting composite material technology for structural component construction in order to obtain reduction of weight, without decrease in vehicle quality and reliability. Properties can be tailored to increase the torque they carry as well as the rotational speed at which they operate. In this project, the conventional propeller shaft has been replaced with different types of material to carry out a comparative analysis, thus determining the most suitable replaceable material

#### II. AIM AND SCOPE OF THE WORK:

The project aims to reduce the weight of the propeller shaft assembly by using different materials. For this project work, the drive shaft of a car was chosen. The modeling of the propeller shaft assembly was done using Catia V5. A Leaf spring has to be designed to meet the stringent design requirements for automobiles. A comparative study of five different materials was conducted to choose the best-suited material. Steel (SM C 45) was chosen for reference and the rest of the five different materials were analyzed. The analysis was carried out using ANSYS 10.0 Workbench for the following materials.

The first was Steel (SM C 45) which was used for reference purpose

Two Composites

- Boron
- Kevlar

And a combination of

- Aluminum
- Glass
- Carbon

#### III. MATERIAL PROPERTIES:

Steel (SM C 45)

Mechanical properties	Symbol	Units	Steel
Young's Modulus	E	GPa	207.0
Shear modulus	G	GPa	80.0
Poisson's ratio	$\nu$	----	0.3
Density	$\rho$	Kg/m <sup>3</sup>	7600
Yield Strength	S <sub>y</sub>	MPa	370
Shear Strength	S <sub>s</sub>	MPa	--

The standard material properties of steel are given as

S.no	parameters	values
1	Outer Radius (R <sub>o</sub> )	0.02m
2	Inner Radius (R <sub>i</sub> )	0.01m
3	Length (L)	0.5m

follows

Table-1: Mechanical Properties of Steel (SMC45)

#### Material Properties for Boron

Density = 2600 kg/m<sup>3</sup>, Young's Modulus = 3 Gpa,  
Poisson's Ratio = 0.21

#### Material Properties for Kevlar

Density = 1440 kg/m<sup>3</sup>, Young's Modulus = 130 Gpa  
,Poisson's Ratio = 0.34

#### Material Properties for Aluminum

Density = 2700 kg/m<sup>3</sup>, Poisson's Ratio = 0.35  
Young's Modulus = 70 Gpa

#### Material properties for Glass

Density = 2540 kg/m<sup>3</sup>, Young's Modulus = 72.4Gpa,  
Poisson's Ratio = 0.34

#### Material Properties for Carbon

Density = 1800 kg/m<sup>3</sup>  
Poisson's Ratio = 0.2  
Young's Modulus = 225 Gpa

### IV. DESIGN CONSIDERATION FOR A PROPELLER SHAFT

#### Description of the Problem:

The fundamental natural bending frequency for passenger cars, small trucks, and vans of the propeller shaft should be higher than 6,500 rpm to avoid whirling vibration and the torque transmission capability of the Propeller shaft should be larger than 3,500 Nm. The Propeller shaft outer diameter should not exceed 100 mm due to space limitations. The Propeller shaft of transmission system is to be designed optimally for following specified design requirements as shown in Table.

S. No	Name	Notation	Units	Value
-------	------	----------	-------	-------

1	Ultimate Torque	T <sub>max</sub>	N-m	3500
2	Max Speed	N <sub>max</sub>	Rpm	6500
3	Max Diameter	D	mm	90

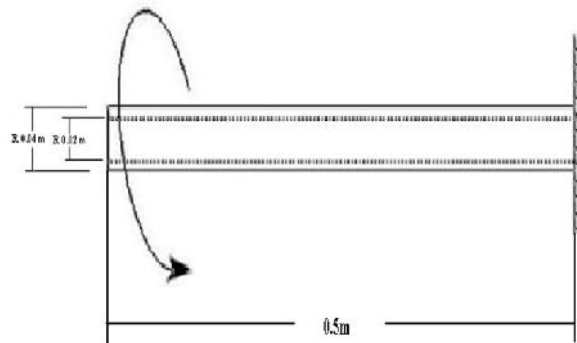

#### Propeller Shaft Design Formulae for Calculations:

##### Deflection:

$$Y_{Max} = \frac{ML^2}{2EI}$$

E = Young's Modulus of Steel (SM C 45)

L = Length of the shaft

I = Moment of inertia

##### Maximum Shear Stress:

$$\tau_{Max} = \frac{T \times R_o}{J}$$

T = Torque

R<sub>o</sub> = Outer Radius

J = Polar Moment of Inertia

##### Maximum Von-Misses Stress:

$$\sigma = \frac{T \times \left(\frac{d_o}{2}\right)}{I}$$

T = Torque

$d_o$  = Outer Diameter

$I$  = Moment of inertia

### Design Calculations

For the hollow shaft, Let

$R_o = 0.04$  m ;  $R_i = 0.02$  m ;  $l = 0.5$  m ;  $E = 207 \times 10^9$  pa  
and Torque=3500 Nm

Where  $R_o$  = Outer Radius

$R_i$  = Inner Radius

$l$  = Length of the shaft

$E$  = Young's Modulus of Steel (SM45C)

$T$  = Applied Torque

$$\text{Deflection} = Y_{\text{Max}} = \frac{ML^2}{2EI} = \frac{3500 \times (0.5^2)}{2 \times (207 \times 10^9) \times (1.178 \times 10^{-7})}$$

$$= 0.0179 \text{ m}$$

Then:

$$\text{Maximum Shear Stress: } \tau_{\text{Max}} = \frac{T \times R_o}{J}$$

$$= \frac{3500 \times 0.02}{\left[\frac{\pi}{32}\right] \times [R_o^4 - R_i^4]}$$

$$= \frac{70}{2.35626 \times 10^{-7}}$$

$$= 2.9708 \times 10^8 \text{ Pa}$$

Maximum Von-Misses Stress:

$$= \frac{[T \times \left(\frac{d_o}{2}\right)]}{I}$$

$$= \frac{3500 \times \left(\frac{0.04}{2}\right)}{\left[\frac{\pi}{64}\right] \times [(0.04)^4 - (0.02)^4]}$$

$$= 594178454.2$$

$$= 5.9417 \times 10^7 \text{ Pa}$$

## V. STRUCTURAL ANALYSIS OF PROPELLER SHAFT

In this work propeller shaft is selected for structural analysis using ANSYS. The various materials using finite element analysis software ANSYS 10.0 CLASIC

### MODELING OF PROPELLER SHAFT IN CATIA V5:

The propeller shaft is designed by required dimensions into the modeling software Catia V5. The geometry of the propeller shaft is designed in Catia V5 is imported to the analysis software in the IGES format.

The designed propeller shaft is below

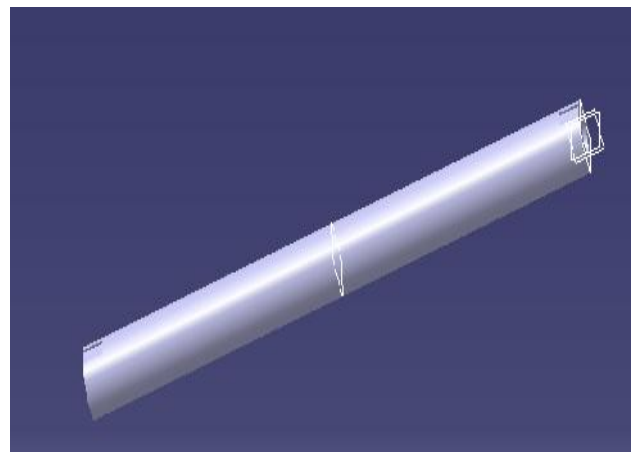
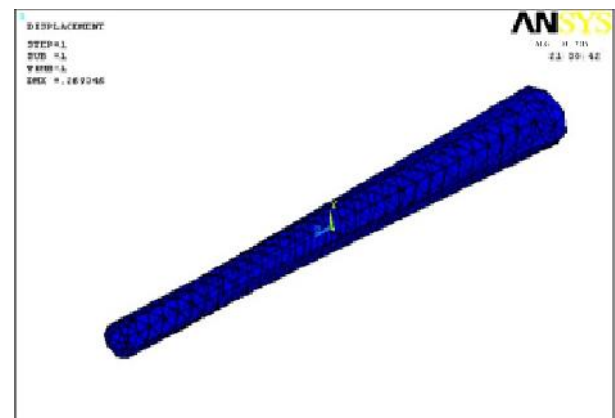

Fig 5.1 Propeller Shaft

### Propeller Shaft Model and Mesh

The modeling of propeller shaft using Catia V5 and the same is used for structural analysis. In this work 8 NODE (SOLID 45) elements selected for meshing. The finite element mesh of the piston model used in ANSYS is shown Figure.



**STRUCTURAL ANALYSIS WITH DIFFERENT MATERIALS**

**5.1.1.1 Structural analysis in steel propeller shaft**

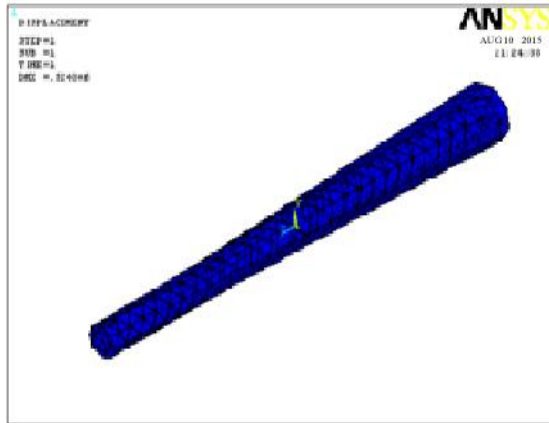

Fig.5.1.1.1 Steel displacement

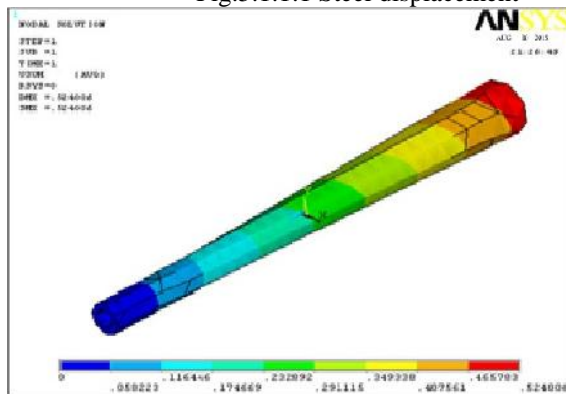

Fig.5.1.1.2 Steel Usim

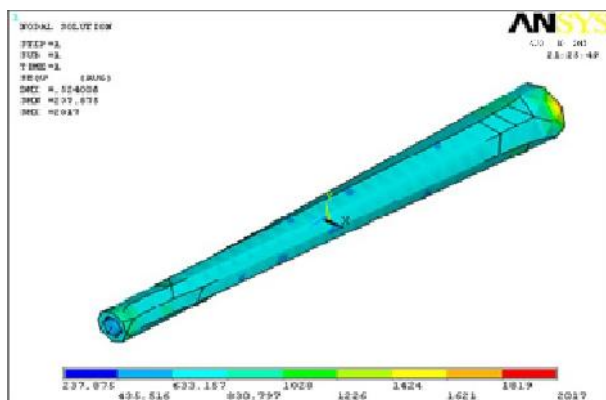

Fig.5.1.1.3 Steel Seqv

**5.1.2: Structural analysis in boron propeller shaft**

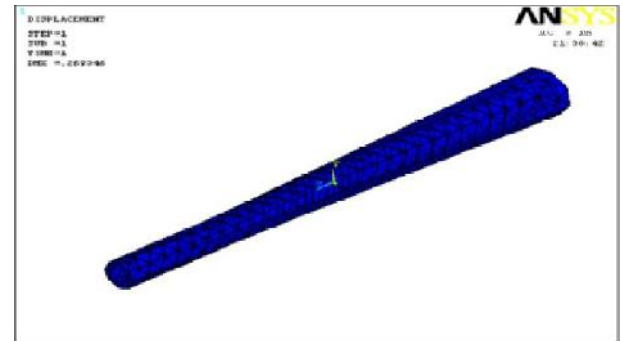

Fig.5.1.2.1 Boron displacement

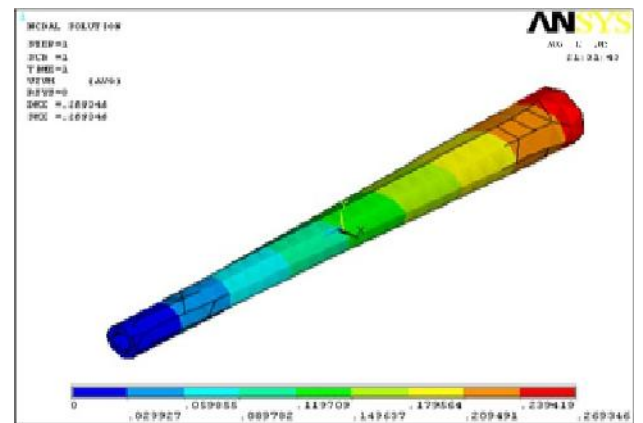

Fig.5.1.2.2 Boron Usim

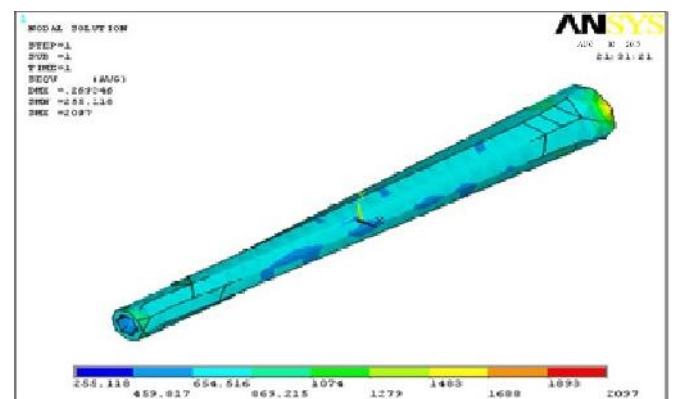

Fig 5.1.2.3 Boron Seqv

**5.1.3 Structural analysis in KEVLAR propeller shaft**

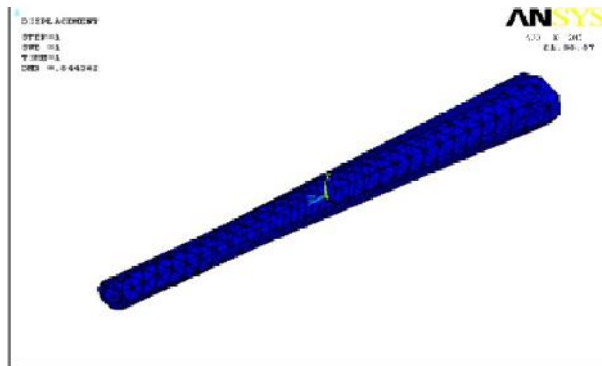

Fig 5.1.3.1 Kevlar displacement

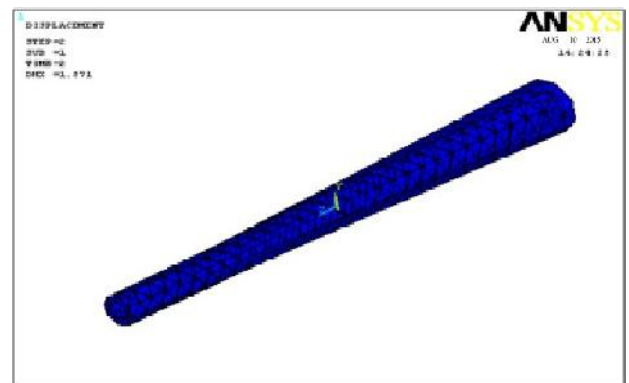

Fig 5.1.4.1 Aluminium displacement

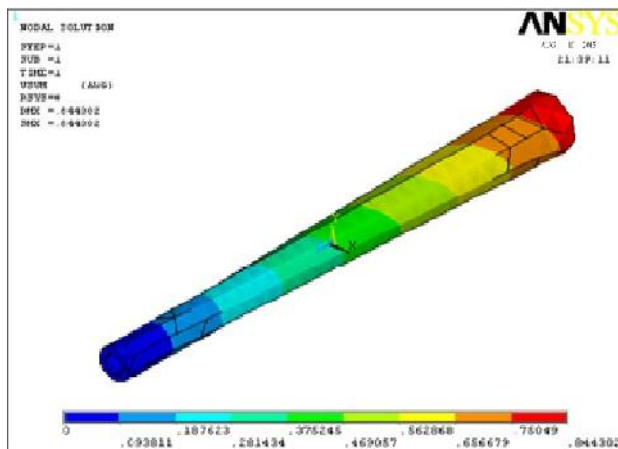

Fig 5.1.3.2 Kevlar Usun

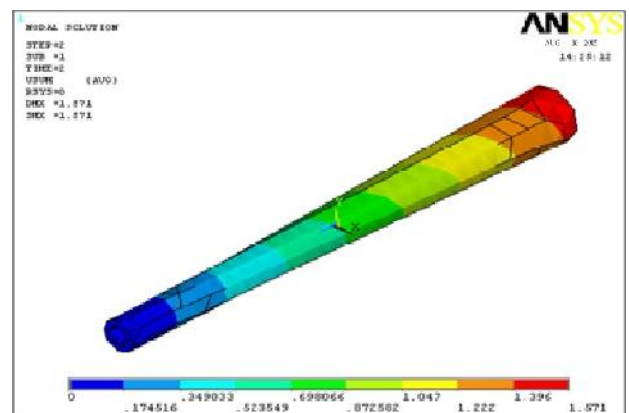

Fig 5.1.4.2 Aluminium Usun

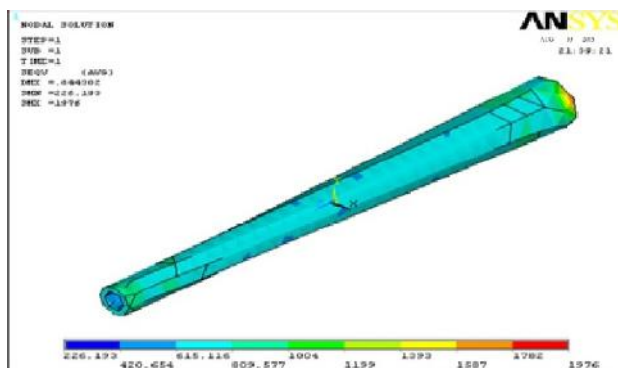

Fig 5.1.3.3 Kevlar Seqv

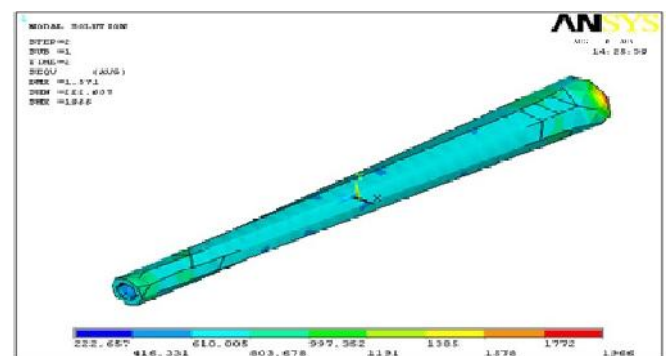

Fig 5.1.4.3 Aluminium Seqv

### 5.1.4 Structural analysis in Aluminium propeller shaft

### 5.1.5: Structural analysis in glass propeller shaft

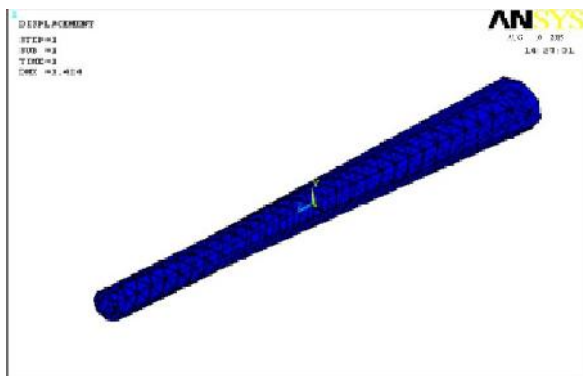

Fig 5.1.5.1 Glass Displacement

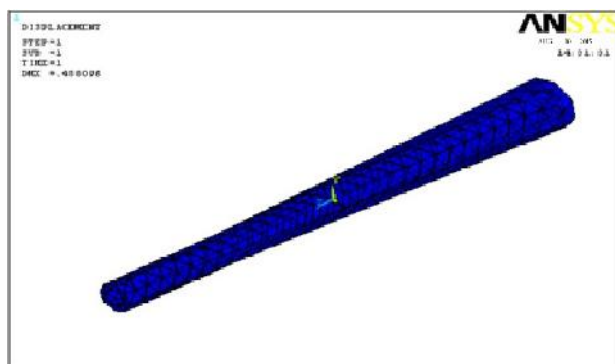

Fig 5.1.6.1 Carbon Displacement

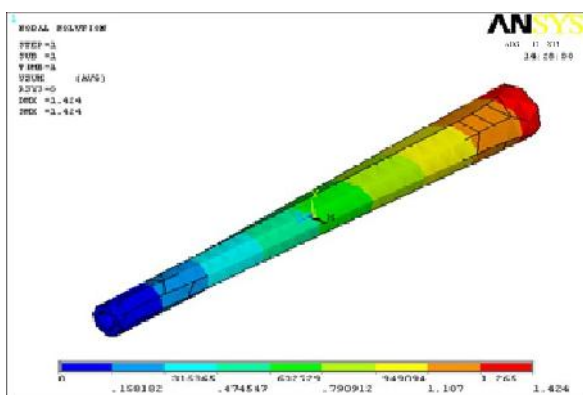

Fig 5.1.5.2 Glass Usum

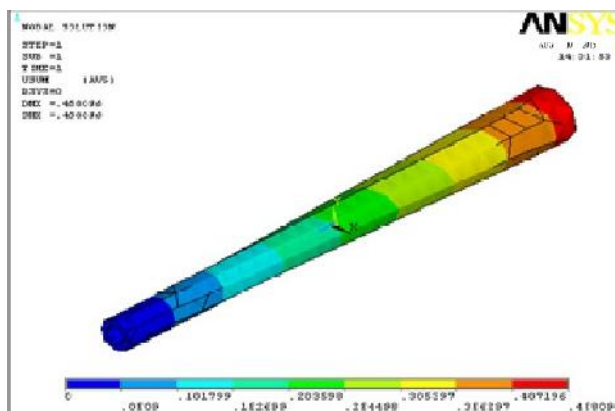

Fig 5.1.6.2 Carbon Usum

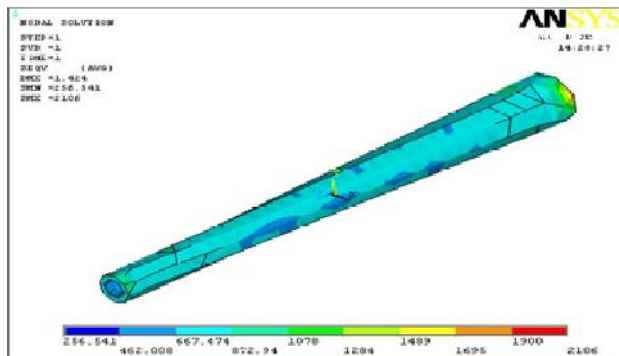

Fig 5.1.5.3 Glass Seqv

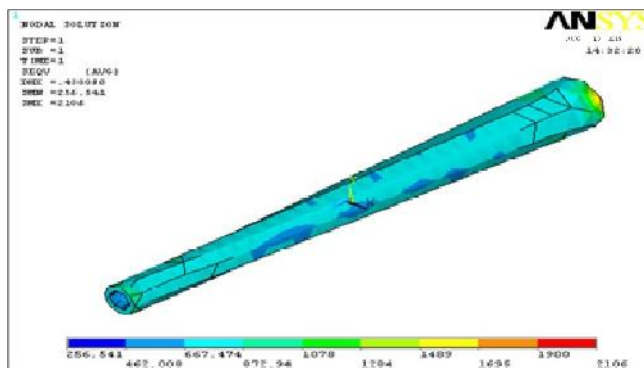

Fig 5.1.6.3 Carbon Seqv

### 5.1.6 Structural analysis in carbon propeller shaft

### VI RESULTS AND DISCUSSIONS:

A total of five materials were chosen for the comparative analysis, including steel, which was used for reference.

S.No	MATERIAL	DEFLECTION Max	STRESS Max	STRESS Min
1	STEEL	0.52401	2017	237.875
2	BORON	0.26935	2097	415.505
3	KEVLAR	0.8443	1976	226.193
4	ALUMINIUM	1.571	1966	222.657
5	GLASS	1.424	2106	256.657
6	CARBON	0.454	2106	256.541

**VI. MODAL ANALYSIS OF PROPELLER SHAFT**

**6.1 STEEL:**

S.NO	FREQUENCY	DEFLECTION MAX
1	682.335	592.787
2	690.768	591.99
3	4191	613.97
4	4259	615.107
5	11282	590.285

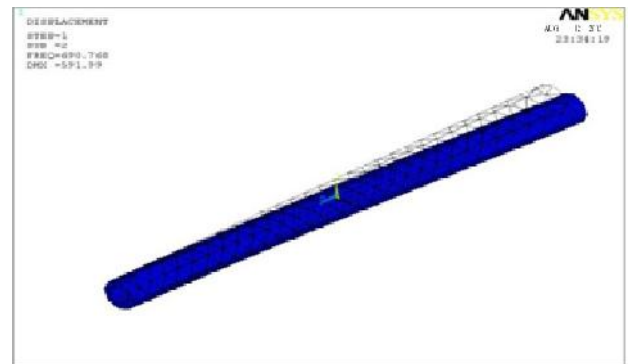

Mode2

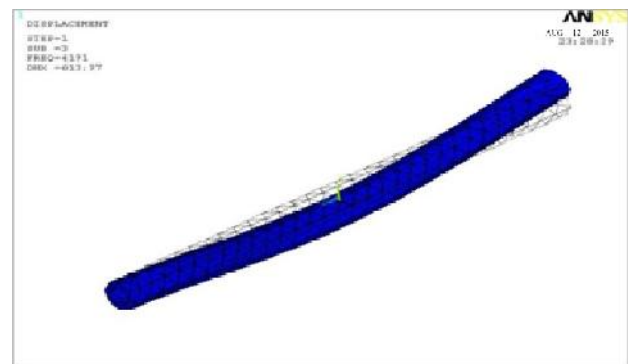

Mode3

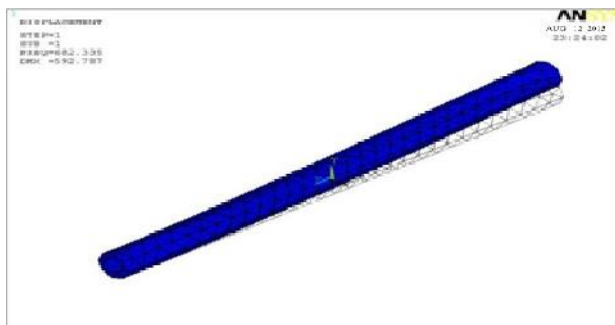

Mode1

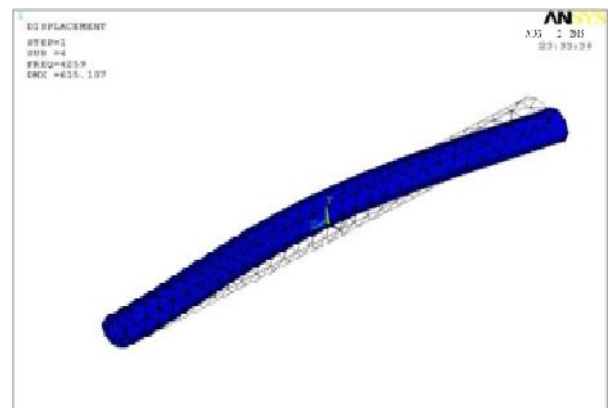

Mode4

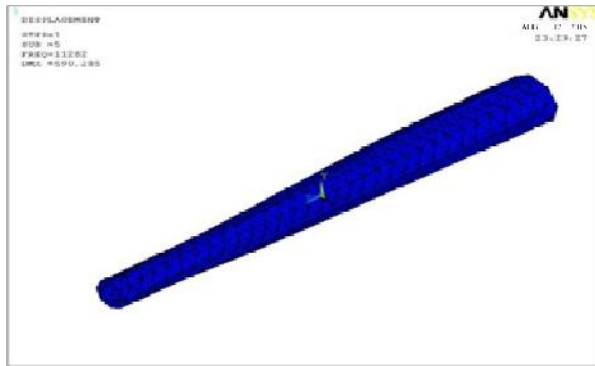

Mode5

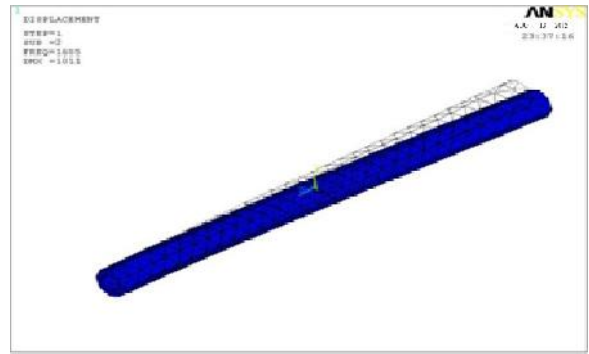

Mode2

### 6.2 BORON

S.NO	FREQUENCY	DEFLECTION MAX
1	<b>1582</b>	<b>1013</b>
2	<b>1605</b>	<b>1011</b>
3	9727	1050
4	9915	1052
5	2645	1055

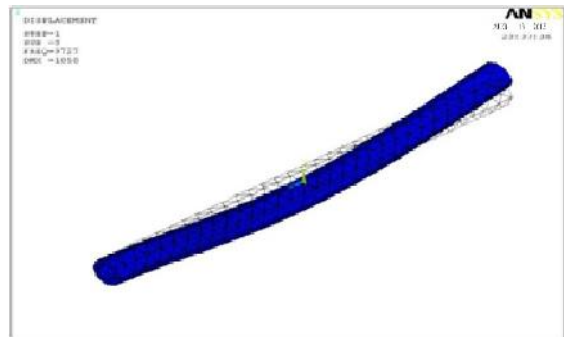

Mode3

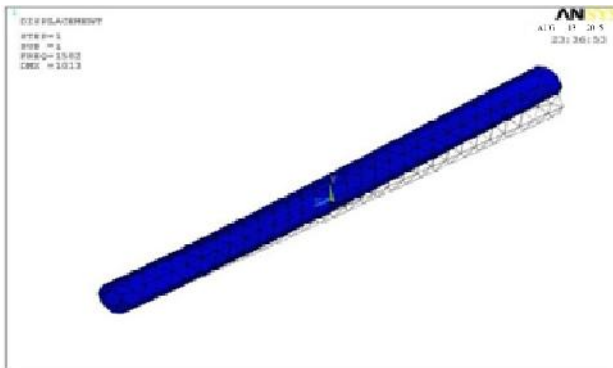

Mode1

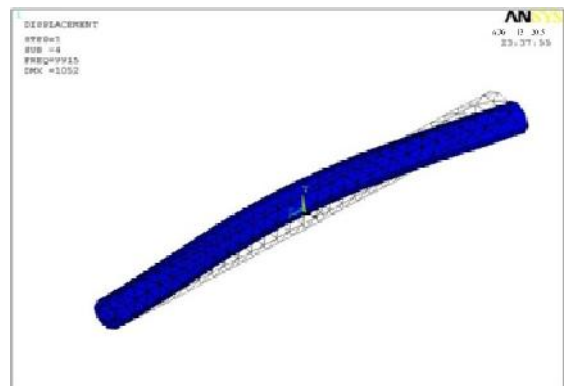

Mode4

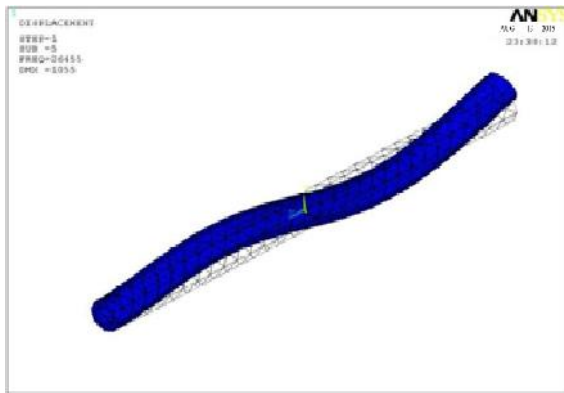

Mode5

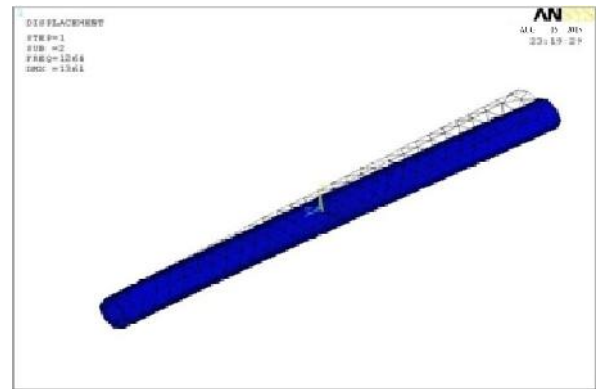

Mode2

**6.3 KEVLAR:**

S.NO	FREQUENCY	DEFLECTION MAX
1	<b>1250.4</b>	<b>1362</b>
2	<b>1264.1</b>	<b>1361</b>
3	7679.9	1411
4	7786.3	1413
5	20414	1342

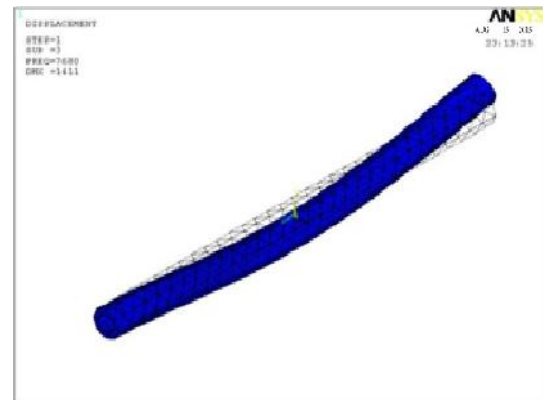

Mode3

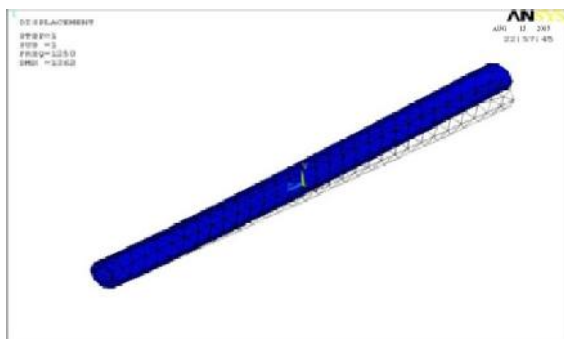

Mode1

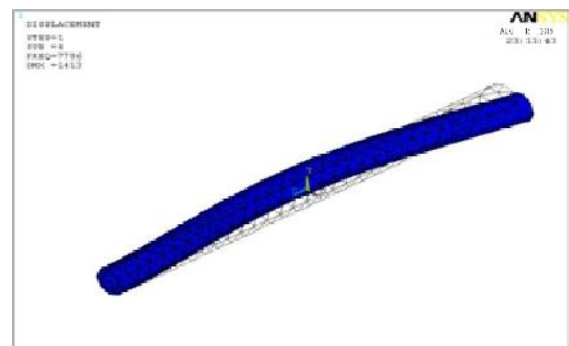

Mode4

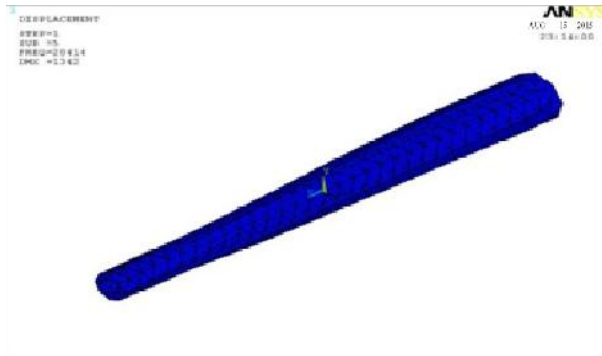

Mode5

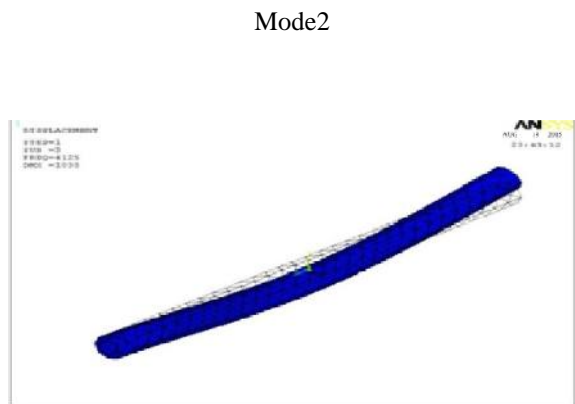

Mode2

**6.4 ALUMINIUM:**

S.NO	FREQUENCY	DEFLECTION MAX
1	<b>671.605</b>	<b>994.756</b>
2	<b>678.653</b>	<b>993.799</b>
3	4125	1030
4	4179	1032
5	10930	979.541

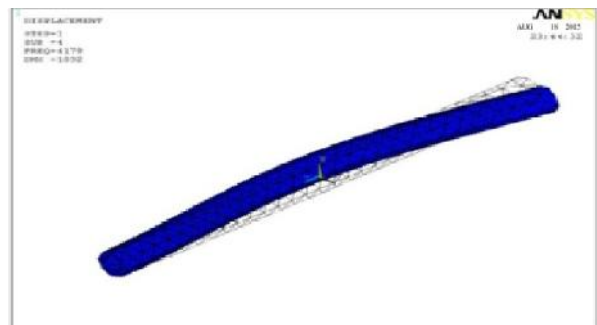

Mode3

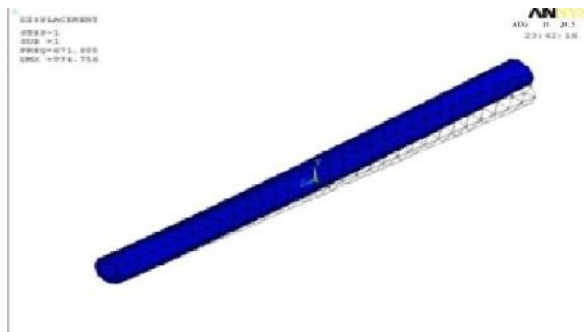

Mode1

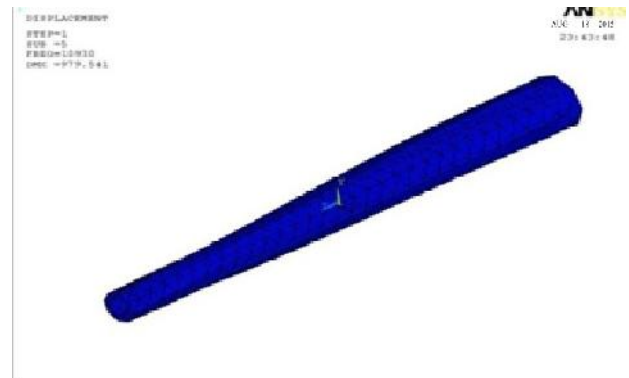

Mode4

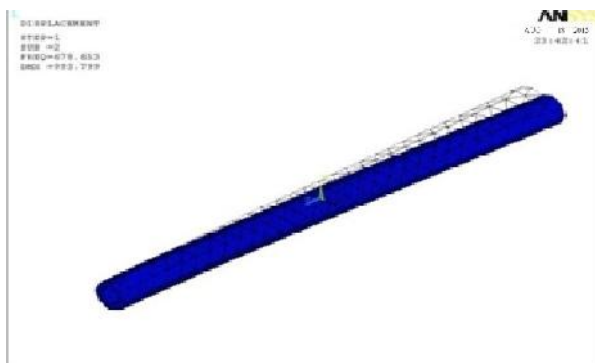

Mode5

**6.5 GLASS:**

S.NO	FREQUENCY	DEFLECTION MAX
1	<b>694.105</b>	<b>1025</b>
2	<b>704.157</b>	<b>1023</b>
3	4268	1062
4	4351	1064
5	11611	1068

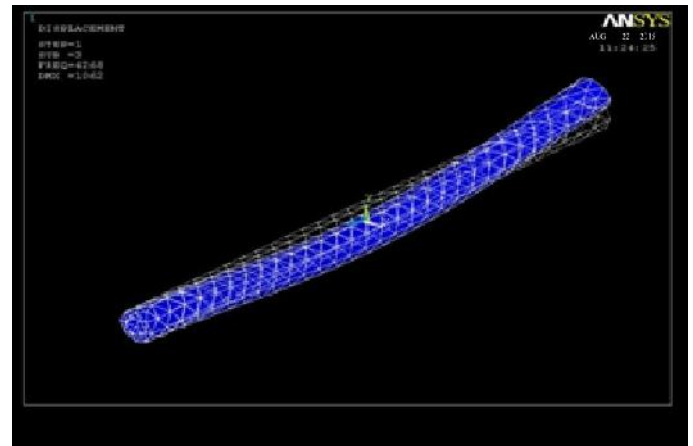

Mode3

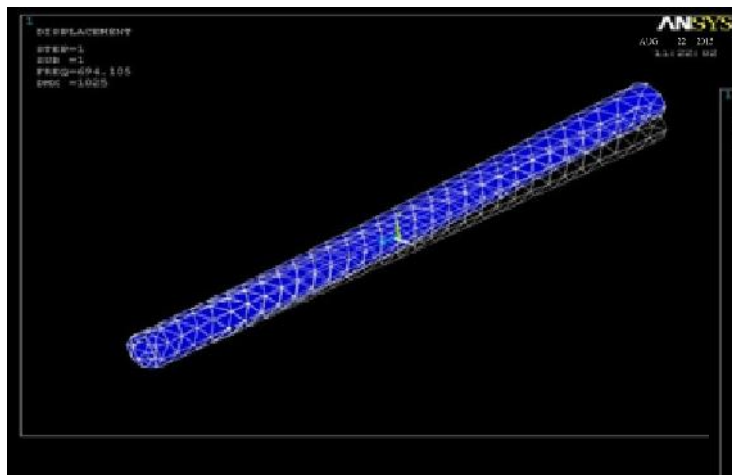

Mode1

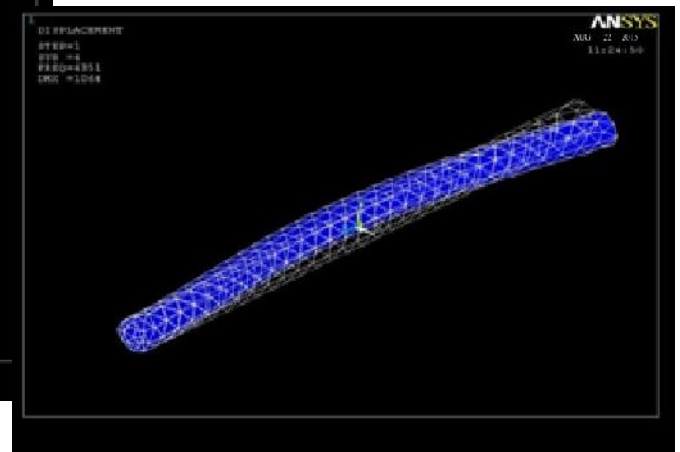

Mode4

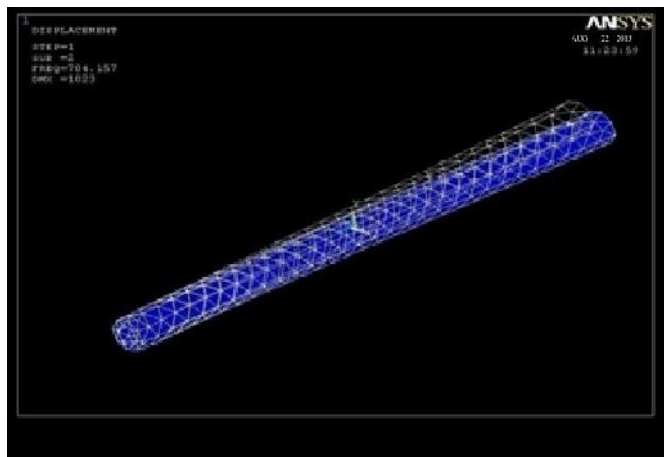

Mode2

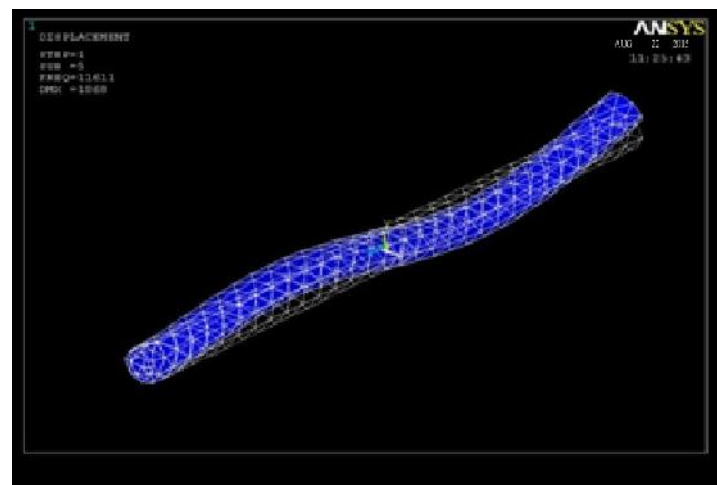

Mode5

**6.6 CARBON:**

S.NO	FREQUENCY	DEFLECTION MAX
1	1454	1217
2	1475	1215
3	8958	1262
4	9112	1264
5	24314	1269

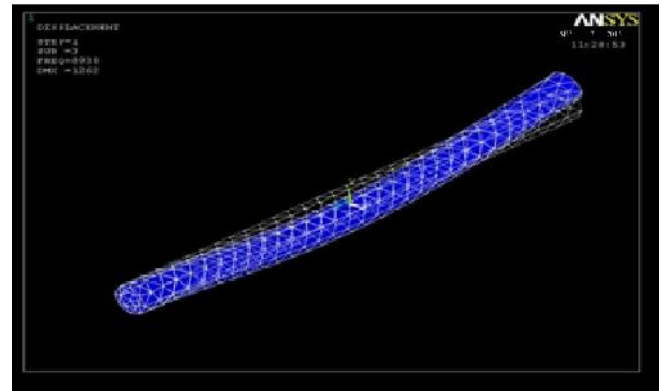

Mode3

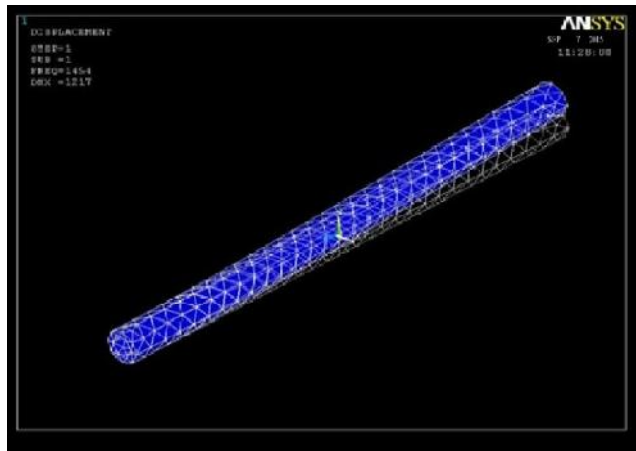

Mode1

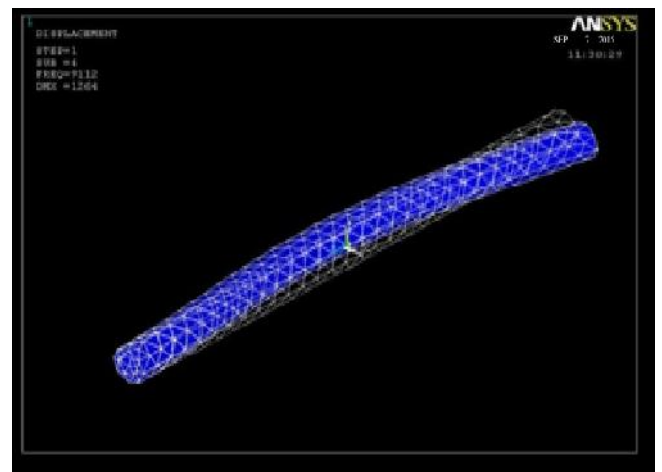

Mode4

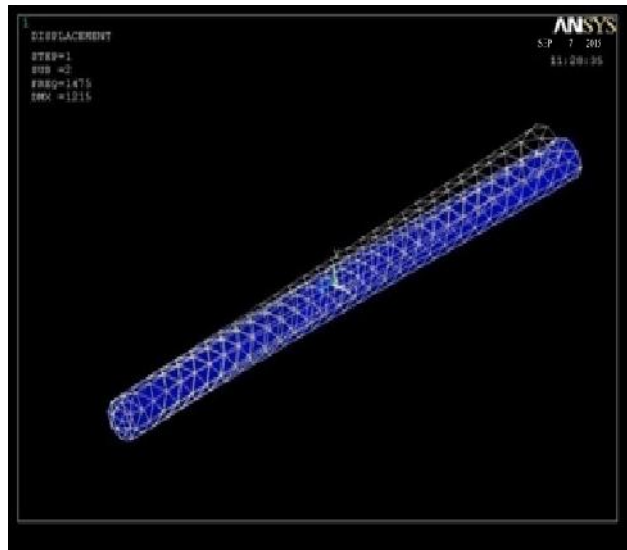

Mode2

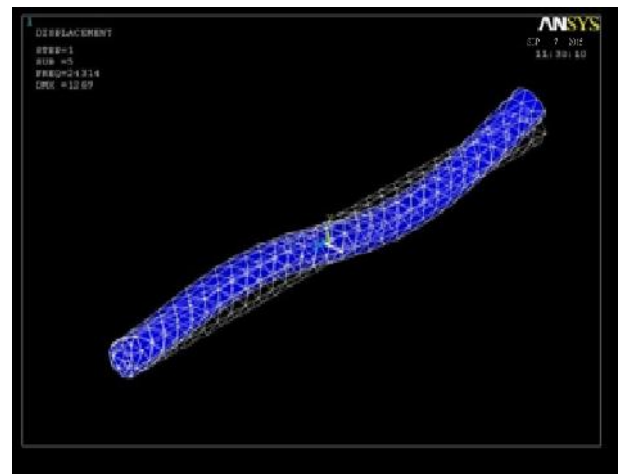

Mode5

**VII CONCLUSION**

The presented work was aimed at reducing the fuel consumption of the automobiles in particular or any

machine, which employs Propeller shafts, in general. This was achieved by reducing the weight of the Propeller shaft with the use of different materials. The Propeller shaft of a vehicle was chosen for determining the dimensions, which were then used for creating a model in Catia V5. Being a complex assembly of a number of parts, it had to be analyzed only for Propeller shaft in ANSYS 10. A total of five materials were chosen for the comparative analysis, including steel, which was used for reference.

Taking into consideration the weight saving, deformation, shear stress induced and resonant frequencies it is observed that Boron has the most encouraging properties to act as the replacement for steel out of all the materials.

#### VIII REFERENCES:

1. A.K. Kaw, Mechanics of Composite Materials, CRC Press, 1997.
2. Dwayne A., "Composites and Advanced Materials" (Centennial of Flight Commemoration Act Public Law 105-389 105<sup>th</sup> Congress (November 13, 1998)). NASA. U.S. Centennial of Flight Commission.(2003).
3. Mallick, P Newman, K. composite materials tech. hanser publishers inc (1990).
4. Vijayarangan, S., Rajendran, I. Optimal Design of a Composite Leaf Spring Using Genetic Algorithm Computers and Structures 79 2001: pp. 1121 – 1129.
5. Beardmore, P. et al. The Potential for Composites in Structural Automotive Applications J. of Composites Science and Technology 26 1986: pp. 251 – 281.