



Thermal Analysis to Estimate Heat Transfer From Heat Sink By Forced Convection Through Open Enclosure

¹J Veerababu ² Sanmala Rajasekhar ³ V.V Ramakrishna ⁴Y.Dhana Sekhar
¹ M. Tech. Student, ² Associate.Professor, ³ Assistant.Professor
Dept Of ME, KITS , DIVILI
⁴ Reserch Scholar

Abstract: Heat Exchanger is a device used to exchange the heat energy between the two fluids by which increases the operating efficiency. These efficiencies plays a major role for cost effective Operations in the process industries. While the both Fluids flow through the heat exchanger, the temperature of both fluids will exchange. The main objective of this paper is deals with the performance rate of double pipe heat exchanger by changing the materials which uses the heat input from the waste recovery of steam in refinery process. Double pipe heat exchangers are designed in CATIA and GAMBIT. CFD analysis is done by using ANSYS. Final Results are obtained with three different types of materials steel, aluminum and copper.

1. INTRODUCTION

Heat sink is an atmosphere capable of spellbinding heat from an object with which it is in thermal contact without a phase change or a considerable change in temperature. The Dissipation of heat reckons on temperature and pressure. The elementary ways of transportation of heat form Heat sinks or thermal reservoirs and etc., are Conduction, Convection, Radiation. Heat transfer changes the internal energy of both systems involved according to the First Law of Thermodynamics. The Second Law of Thermodynamics defines the concept of thermodynamic entropy. The course of heat transfer between a surface and a fluid flowing in contact with it is called convection. If the flow is did by an external device like a pump or blower, it is named as forced convection. If the flow is caused by the floating (buoyant) forces brought forth by heating or temperature reduction of the fluid the process is called as natural or free Convection transfers heat via the motion of a fluid which contains thermal energy. In an environment where a constant gravitational force $F = mg$ acts on every object of mass m , convection develops naturally as of changes in the

fluids concentration with temperature. When a fluid, such as air or water, is in contact with a hotter object, it picks up thermal energy by conduction. Its concentration decreases. For a given volume of the fluid, the upward buoyant force equals the weight of this volume of cool fluid. The downward force is the weight of this volume of hot fluid. The upward force has a larger magnitude than the downward force and the volume of hot fluid rises. Similarly, when a fluid is in contact with a colder object, it cools and sinks.

1.1 Thermal Boundary Layer

Athermal boundary layer builds ups when a fluid at a particular temperature flows over a surface that is at a different temperature, as shown in figure below

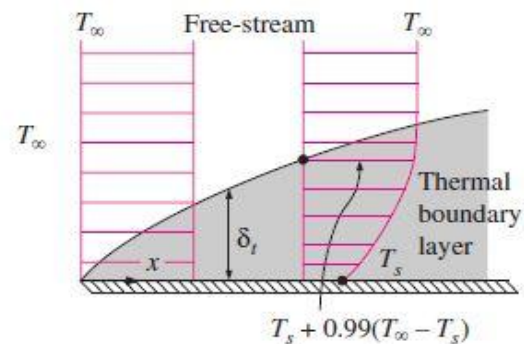

Consider the flow of a fluid at a consistent temperature of T over an isothermal flat plate at temperature T_s . The fluid particles in the layer adjacent to the surface will reach thermal balance with the plate and assume the surface temperature T_s . These fluid subdivisions will then swap over energy with the particles in the neighboring-fluid layer, and so on. As a result, a temperature profile will extend in the flow field that ranges from T_s at the surface to T sufficiently far-off from the surface. The flow district over the surface in which the temperature difference in the direction normal to the surface is important is

the thermal boundary layer. The *thickness* of the thermal boundary layer δ_t at any place along the surface is definite as the reserve from the surface at which the temperature difference $T - T_s$ equals $0.99(T - T_s)$. Note that for the special case of $T_s = 0$, we have $T = 0.99T$ at the outer edge of the thermal boundary layer, which is analogous to $u = 0.99u$ for the velocity boundary layer. The thickness of the thermal boundary layer increases in the flow course, since the effects of heat transfer are felt at greater spaces from the surface further downstream. The convection heat transfer rate wherever along the surface is directly related to the temperature gradient at that position. Therefore, the shape of the temperature profile in the thermal boundary layer say aloud the convection heat transfer between a solid surface and the fluid flowing over it. In flow over a heated (or cooled) surface, both velocity and thermal boundary layers will develop concurrently. Noting that the fluid velocity will have a strong power on the temperature profile, the development of the velocity boundary layer comparative to the thermal boundary layer will have a strong effect on the convection heat transfer.

1.2 Introduction to CATIA

CATIA also known as Computer Aided Three-dimensional Interactive Application and it is software suit that developed by the French company call Dassult Systems.

CATIA is a process-centric computer-aided design/computer-assisted manufacturing/computer-aided engineering (CAD/CAM/CAE) system that fully uses next generation object technologies and leading edge industry standards. CATIA is integrated with Dassult Systems Product Lifecycle Management (PLM) solutions. It allows the users to simulate their industrial design processes from initial concept to product design, analysis, assembly and also maintenance. In this software, it includes mechanical, and shape design, styling, product synthesis, equipment and systems engineering, NC manufacturing, analysis and simulation, and industrial plant design. It is very user friendly software because CATIA Knowledge ware allows broad communities of user to easily capture and share know-how, rules, and other intellectual property assets.

1.3 Introduction to Ansys

ANSYS is general-purpose finite element analysis (FEA) software package. Finite Element Analysis is a numerical method of deconstructing a complex system into very small pieces (of user-designated size) called elements. The software implements equations that govern the behaviour of

these elements and solves them all; creating a comprehensive explanation of how the system acts as a whole. These results then can be presented in tabulated, or graphical forms. This type of analysis is typically used for the design and optimization of a system far too complex to analyse by hand. Systems that may fit into this category are too complex due to their geometry, scale, or governing equations.

ANSYS is the standard FEA teaching tool within the Mechanical Engineering Department at many colleges. ANSYS is also used in Civil and Electrical Engineering, as well as the Physics and Chemistry departments.

ANSYS provides a cost-effective way to explore the performance of products or processes in a virtual environment. This type of product development is termed virtual prototyping. With virtual prototyping techniques, users can iterate various scenarios to optimize the product long before the manufacturing is started. This enables a reduction in the level of risk, and in the cost of ineffective designs. The multifaceted nature of ANSYS also provides a means to ensure that users are able to see the effect of a design on the whole behaviour of the product, be it electromagnetic, thermal, mechanical etc.

2. Thermal Analysis Of Heat Sink Original Model Using Material Aluminum 1050a

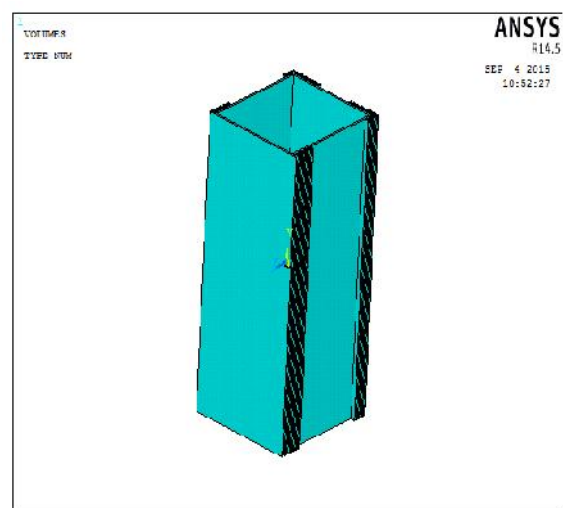

Fig.1 Import Model

3. Thermal Analysis Of Heat Sink Original Model Using Material Copper Alloys

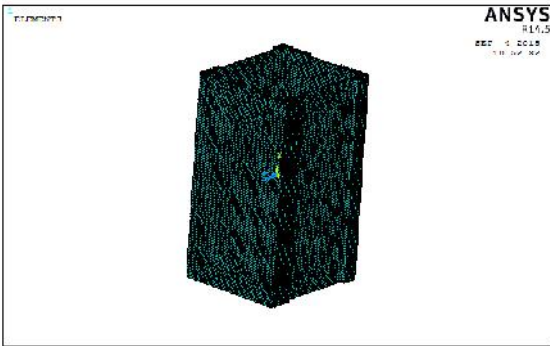

Fig.2 Meshed Model

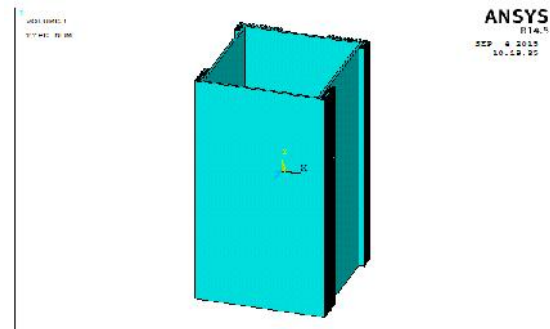

Fig.6 Impred Model

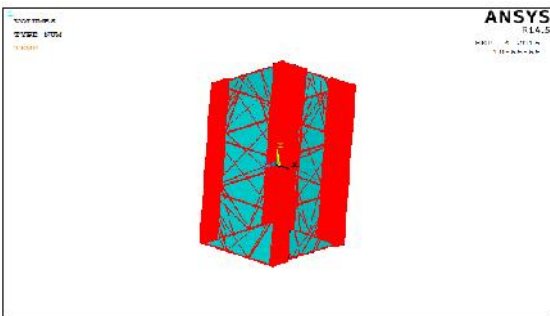

Fig.3 Loads Applied Model

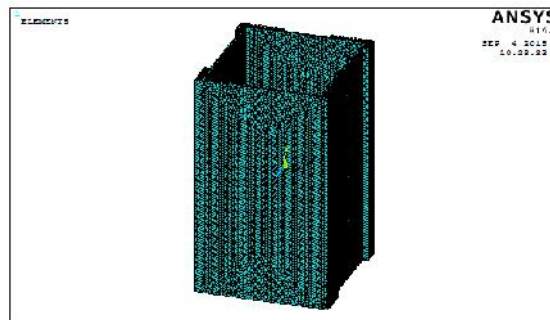

Fig.7 Meshed Model

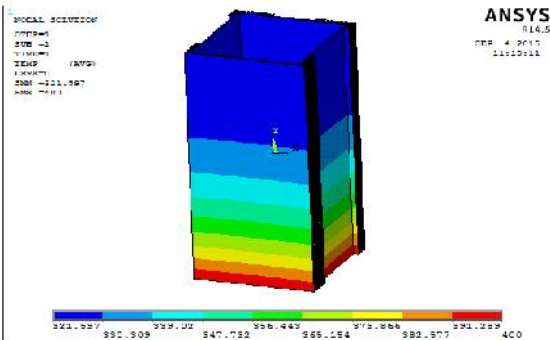

Fig.4 Nodal Temperature

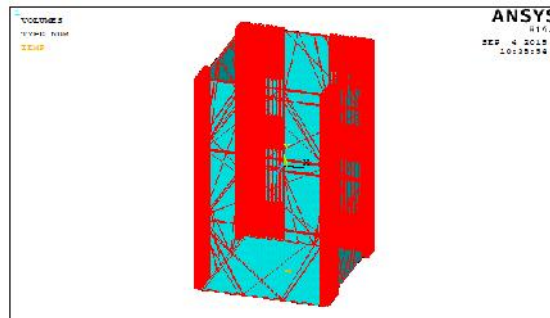

Fig.8 Loads Applied Model

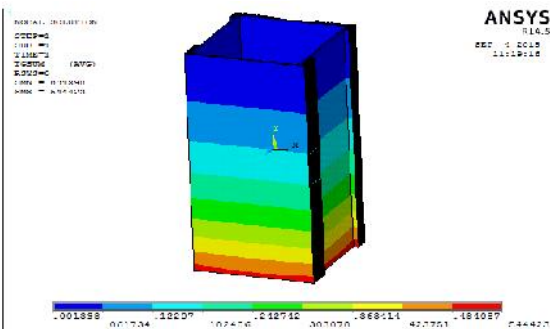

Fig.5 Thermal Gradient

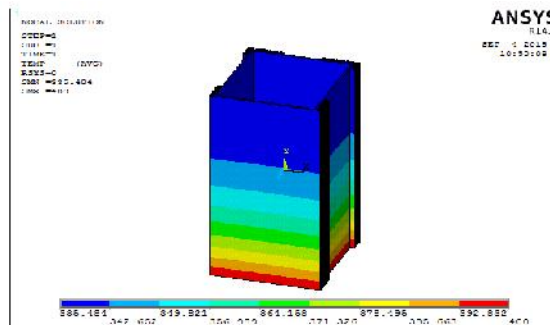

Fig.9 Nodal Temperature

4. Thermal Analysis Of Heat Sink Modified Model Using Material Aluminum 1050a

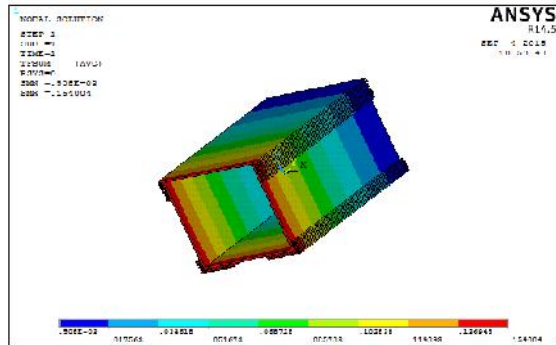

Fig.10 Thermal flux

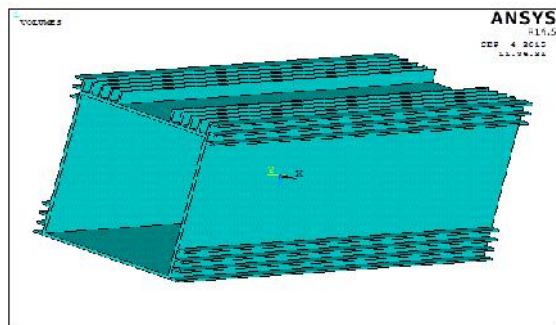

Fig.11 Imported Model

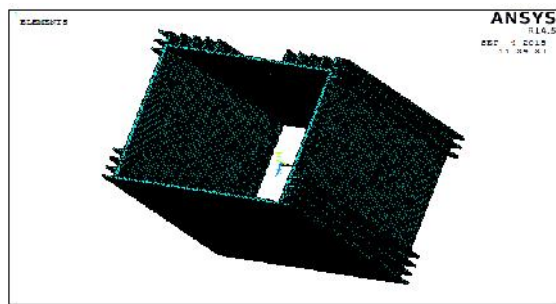

Fig.12 Meshed Model

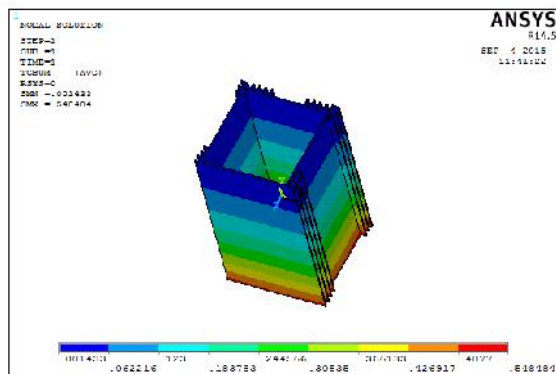

Fig.13 Thermal Gradient

5. CFD Analysis original Model In Ansys Work Bench

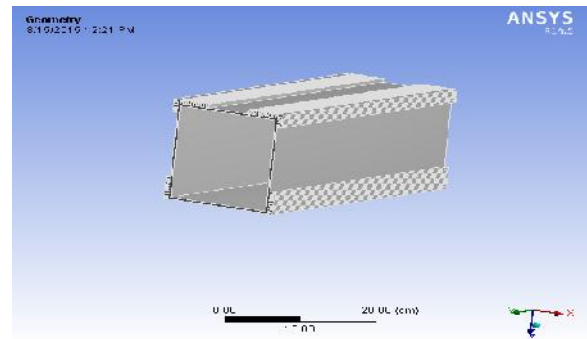

Fig.14 work bench model

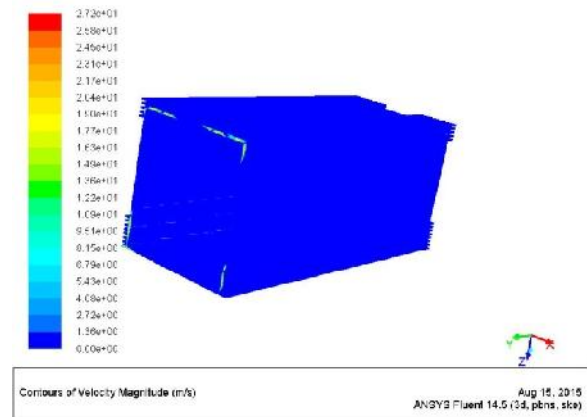

Fig.15 Velocity

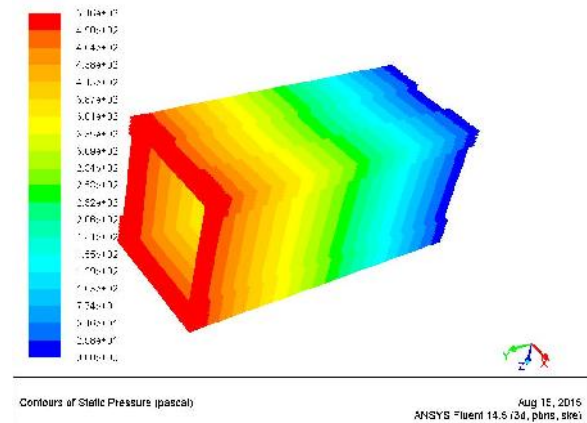

Fig.16 Pressure

6. RESULT

Heat Sink

6.1 Thermal Analysis Of Original Model

	TEMPERATURE		THERMAL GRADIENT		THERMAL FLUX	
	MIN	MAX	MIN	MAX	MIN	MAX
Aluminum 1050a	321.597	400	0.001398	0.544423	3.23e-04	0.125762
Copper	335.484	400	0.00132	0.400009	5.08e-04	0.15404
Aluminum He-15	378.964	400	4.93e-04	0.112037	0.075961	17.2537
Aluminum 6063	382.42	400	4.17e-04	0.092546	0.080459	17.8615

6.2 Thermal Analysis Of Modified Model

	Temperature		Thermal Gradient		Thermal Flux	
	Min	Max	Min	Max	Min	Max
Aluminum 1050a	321.679	400	0.001433	0.548484	3.31e-04	0.1267
Copper	335.597	400	0.001351	0.402271	5.20e-04	0.154874
Aluminum He-15	378.776	400	5.04e-04	0.11389	0.077562	17.5391
Aluminum 6063	382.267	400	4.26e-04	0.94039	0.082254	18.1495

6.3 CFD Analysis

	Velocity		Temperature	Pressure	Density	Shear Stress
	Min	Max				
Original	0.00E+00	2.72E+01	3.17E+02	5.16E+02	1.23E+00	3.22E+00
Modified	5.56E+00	3.10E+01	3.17E+02	5.45E+02	1.23E+00	3.22E+00

CONCLUSION

Heat sink is an object that disperses heat from another objects, these are commonly found in computers, refrigerators etc. here in this project we have designed a heat sink with an open enclosure in refrigeration will be analyzed for the heat transfer by forced convection using CATIA V5. Here we have even designed a modified model also for the heat sink.

Design has been modified as to compare the results with the original and even to get the better efficiency and even the better heat transfer rate.

Thermal and CFD analysis are done to the heat sink to determine the heat transfer rates for the materials ALUMINUM 1050A, COPPER, ALUMINUM HE-15 AND ALUMINUM 6063 ALLOY. Analysis is done to the original model as well as to the modified model. As observed in the graphs and tables obtained heat sink which is made up of ALUMINUM 1050A will be a better object that too for the modified model.

REFERENCES

- The scientific design of exhaust and intake systems by Philip Hubert Smith, John Cruickshank Morrison, R. Bentley, 1971
- The Design and Tuning of Competition Engines by Philip Hubert Smith, BENTLEY ROBERT Incorporated, 1977
- Automobile Engines - In Theory, Design, Construction, Operation, Testing and Maintenance by A.W. Judge
- Silicon Nitride (Si3N4) Properties and Applications
<http://www.azom.com/properties.aspx?ArticleID=53>
- Zinc Oxide (ZnO2) Properties and Applications
<http://www.azonano.com/article.aspx?ArticleID=334>

8