



A DCM Based PFC CUK Converter-Speed Adjustable BLDC Drive

Apparao Bera¹, N.Sirisha²

¹PG Scholar, Pydah College of Engineering, Kakinada, AP, India.

²Associate Professor, Pydah College of Engineering, Kakinada, AP, India.

Abstract—This paper proposes a DCM based PFC cuk converter-speed adjustable BLDC drive. This system has major advantages like: it is a money-making solution for low-power applications and it operates in discontinuous conduction mode also. The speed of the BLDC motor is controlled by dc-bus voltage of a voltage source inverter (VSI). VSI uses a low switching frequency to reduce the switching losses. A diode bridge rectifier followed by a Cuk converter functioning in a discontinuous conduction mode (DCM) is used for control of dc-link voltage. And also it will keep unity power factor at ac mains. Performance of the PFC Cuk converter is evaluated under four different operating conditions of discontinuous and continuous conduction modes (CCM). The performance of the proposed system is simulated in MATLAB/Simulink environment to validate its performance over a wide range of speed with unity power factor at ac mains.

Index Terms—Brushless dc (BLDC) motor, Cuk converter, discontinuous conduction mode (DCM), power factor correction (PFC).

I. INTRODUCTION

BLDC motors are recommended for many low- and medium-power drives applications because of their high efficiency, high flux density per unit volume, low maintenance requirement, low electromagnetic interference (EMI) problems, high ruggedness, and a wide range of speed control. Due to these advantages, they find applications in numerous areas such as household application, transportation (hybrid vehicle), aerospace, heating, ventilation and air conditioning, motion control and robotics, renewable energy applications etc. The BLDC motor is a three-phase synchronous motor consisting of a stator having a three-phase concentrated windings and a rotor having permanent magnets.

There is a requirement of an improved power quality (PQ) as per the international PQ standard IEC

61000-3-2 which recommends a high power factor (PF) and low total harmonic distortion (THD) of ac mains current for Class-A applications (<600 W, <16 A) which includes many household equipments. The conventional scheme of a BLDC motor fed by a diode bridge rectifier (DBR) and a high value of dc-link capacitor draws a nonsinusoidal current, from ac mains which is rich in harmonics such that the THD of supply current is as high as 65%, which results in PF as low as 0.8. These types of PQ indices cannot comply with the international PQ standards such as IEC 61000-3-2. Hence, single-phase power factor correction (PFC) converters are used to attain a unity PF at ac mains.

These converters have gained attention due to single-stage requirement for dc-link voltage control with unity PF at ac mains. It also has low component count as compared to a multistage converter and therefore offers reduced losses. Conventional schemes of PFC converter-fed BLDC motor drive utilize an approach of constant dc-link voltage of the VSI and controlling the speed by controlling the duty ratio of high frequency pulse width modulation (PWM) signals. The losses of VSI in such type of configuration are considerable since switching losses depend on the square of switching frequency ($P_{sw} \text{ loss} \propto f_2 S$). Ozturk *et al.* have proposed a boost PFC converter-based direct torque controlled (DTC) BLDC motor drive.

They have the disadvantages of using a complex control which requires large amount of sensors and higher end digital signal processor (DSP) for attaining a DTC operation with PFC at ac mains. Hence, this scheme is not suited for low-cost applications. Ho *et al.* have proposed an active power factor correction scheme which uses a PWM switching of VSI and hence has high switching losses. Wu *et al.* have proposed a cascaded buck-boost converter-fed BLDC motor drive, which utilizes two switches for PFC operation. This offers high switching losses in the front-end converter due to double switch and reduces the efficiency of the overall system. Gopalarathnam *et al.* have proposed a single-ended primary inductance

converter (SEPIC) as a front-end converter for PFC with a dc-link voltage control approach, but utilizes a PWM switching of VSI which has high switching losses. Bridgeless configurations of PFC buck-boost, Cuk, SEPIC, and Zeta converters have been proposed in [22]–[25], respectively.

These configurations offer reduced losses in the front-end converter but at the cost of high number of passive and active components. Selection of operating mode of the front-end converter is a tradeoff between the allowed stresses on PFC switch and cost of the overall system. Continuous conduction mode (CCM) and discontinuous conduction mode (DCM) are the two different modes of operation in which a front-end converter is designed to operate [16], [17]. A voltage follower approach is one of the control techniques which is used for a PFC converter operating in the DCM. This voltage follower technique requires a single voltage sensor for controlling the dc-link voltage with a unity PF. Therefore, voltage follower control has an advantage over a current multiplier control of requiring a single voltage sensor.

This makes the control of voltage follower a simple way to achieve PFC and dc-link voltage control, but at the cost of high stress on PFC converter switch. On the other hand, the current multiplier approach offers low stresses on the PFC switch, but requires three sensors for PFC and dc-link voltage control. Depending on design parameters, either approach may force the converter to operate in the DCM or CCM. In this study, a BLDC motor drive fed by a PFC Cuk converter operating in four modes/control combinations is investigated for operation over a wide speed range with unity PF at ac mains. These include a CCM with current multiplier control, and three DCM techniques with voltage follower control.

II. SYSTEM CONFIGURATION

Figs. 1 and 2 show the PFC Cuk converter-based VSI-fed BLDC motor drive using a current multiplier and a voltage follower approach, respectively. A high frequency MOSFET is used in the Cuk converter for PFC and voltage control, whereas insulated-gate bipolar transistors (IGBTs) are used in the VSI for its low frequency operation. The BLDC motor is commutated electronically to operate the IGBTs of VSI in fundamental frequency switching mode to reduce its switching losses. The PFC Cuk converter operating in the CCM using a current multiplier approach is shown in Fig. 1; i.e., the current flowing in the input and output inductors (L_i and L_o),

and the voltage across the intermediate capacitor (C_1) remain continuous in a switching period, whereas Fig. 2 shows a Cuk converter-fed BLDC motor drive operating in the DCM using a voltage follower approach. The current flowing in either of the input or output inductor (L_i and L_o) or the voltage across the intermediate capacitor (C_1) becomes discontinuous in a switching period for a PFC Cuk converter operating in the DCM. A Cuk converter is planned to operate in all three DCMs and a CCM of operation and its performance is evaluated for a wide voltage control with unity PF at ac mains.

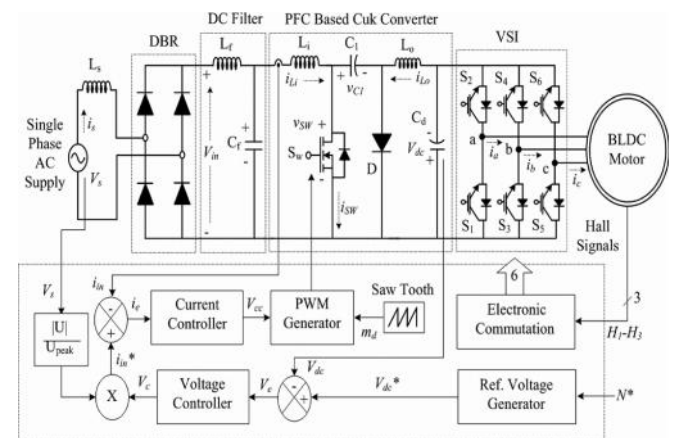

Fig. 1 BLDC motor drive fed by a PFC Cuk converter using a current multiplier approach

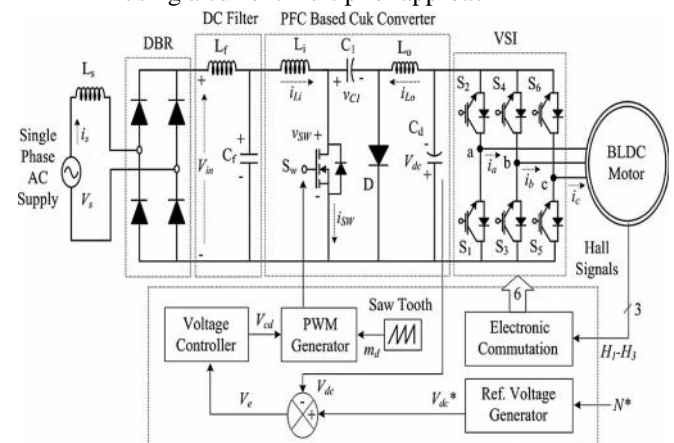

Fig. 2 BLDC motor drive fed by a PFC Cuk converter using a voltage follower approach

III. OPERATION OF THE CUK CONVERTER

The operation of the Cuk converter is studied in four different modes of CCM and DCM. In CCM, the current in inductors (L_i and L_o) and voltage across intermediate capacitor C_1 remain continuous in a switching period. Moreover, the DCM operation is further classified into two broad categories of a discontinuous inductor current mode (DICM) and a

discontinuous capacitor voltage mode (DCVM). In the DICM, the current flowing in inductor L_i or L_o becomes discontinuous in their respective modes of operation. While in DCVM operation, the voltage appearing across the intermediate capacitor C_1 becomes discontinuous in a switching period. Different modes for operation of the CCM and DCM are discussed as follows.

A. CCM Operation

The operation of the Cuk converter in the CCM is described as follows. Fig. 3(a) and (b) shows the operation of the Cuk converter in two different intervals of a switching period and Fig. 3(c) shows the associated waveforms in a complete switching period.

Interval I: When switch S_w is turned ON, inductor L_i stores energy while capacitor C_1 discharges and transfers its energy to dc-link capacitor C_d as shown in Fig. 3(a). Input inductor current i_{Li} increases while the voltage across the intermediate capacitor V_{C1} decreases as shown in Fig. 3(c).

Interval II: When switch S_w is turned OFF, the energy stored in inductor L_o is transferred to dc-link capacitor C_d , and inductor L_i transfers its stored energy to the intermediate capacitor C_1 as shown in Fig. 3(b). The calculated values of L_i , L_o , and C_1 are large enough such that a finite amount of energy is always stored in these mechanism in a switching period.

B. DICM (L_i) Operation

The operation of the Cuk converter in the DICM (L_i) is described as follows. Fig. 4(a)–(c) shows the operation of the Cuk converter in three different intervals of a switching period and Fig. 4(d) shows the associated waveforms in a switching period.

Interval I: When switch S_w is turned ON, inductor L_i stores energy while capacitor C_1 discharges through Switch S_w to transfer its energy to the dc-link capacitor C_d as shown in Fig. 4(a). Input inductor current i_{Li} increases while the voltage across the capacitor C_1 decreases as shown in Fig. 4(d).

Interval II: When switch S_w is turned OFF, the energy stored in inductor L_i is transferred to intermediary capacitor C_1 via diode D, till it is completely discharged to enter DCM operation.

Interval III: During this interval, no energy is left in input inductor L_i ; hence, current i_{Li} becomes zero. Moreover, inductor L_o operates in continuous conduction to convey its energy to dc-link capacitor C_d .

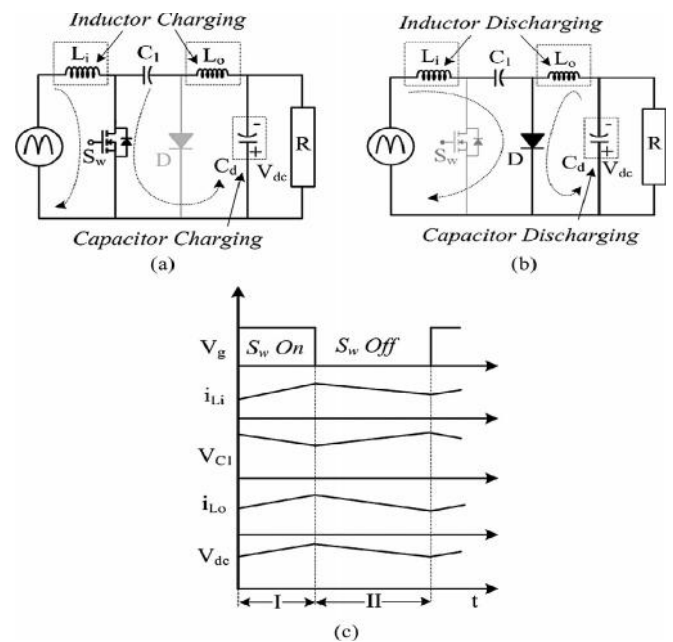

Fig. 3 Operation of the Cuk converter in the CCM during (a, b) different intervals of switching period and (c) associated waveforms (a) Interval I (b) Interval II (c) Waveforms

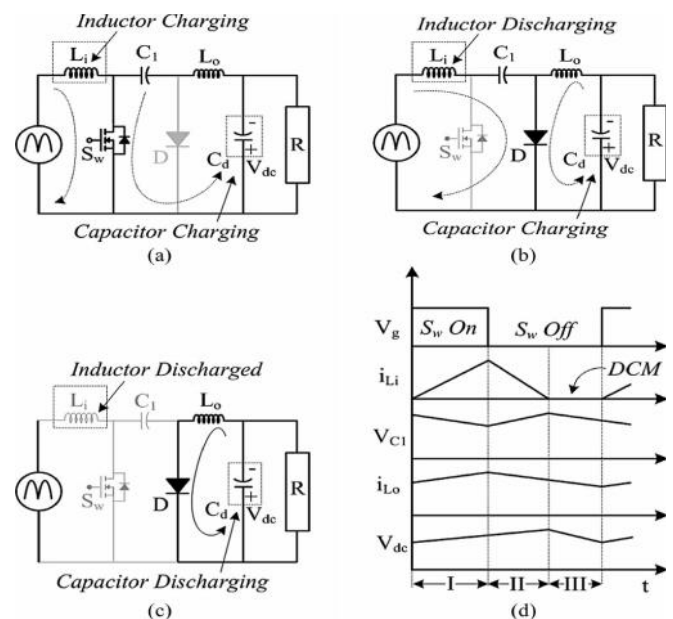

Fig. 4 Operation of the Cuk converter in the DICM (L_i) during (a)–(c) different intervals of switching period and (d) associated waveforms (a) Interval I (b) Interval II (c) Interval III (d) Waveforms

C. DICM (L_o) Operation

The operation of the Cuk converter in the DICM (L_o) is described as follows. Fig. 5(a)–(c) shows the operation of the Cuk converter in three different intervals of a switching period and Fig. 5(d) shows the associated waveforms in a switching period.

Interval I: As shown in Fig. 5(a), when switch S_w in turned ON, inductor L_i stores energy while capacitor C_1 discharges through switch S_w to transfer its energy to the dc-link capacitor C_d .

Interval II: When switch S_w is turned OFF, the energy stored in inductor L_i and L_o is transferred to intermediate capacitor C_1 and dc-link capacitor C_d , respectively.

Interval III: In this mode of operation, the output inductor L_o is completely discharged; hence, its current i_{L_o} becomes nil. An inductor L_i operates in continuous conduction to transfer its energy to the intermediate capacitor C_1 via diode D .

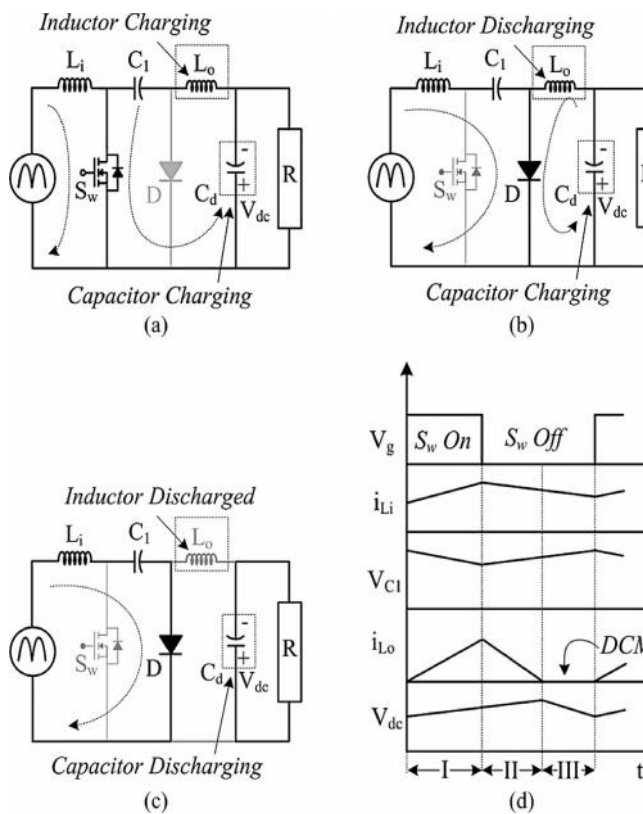

Fig. 5 Operation of the Cuk converter in DICM (L_o) during (a)–(c) different intervals of switching period and (d) associated waveforms (a) Interval I (b) Interval II (c) Interval III (d) Waveforms

D. DCVM (C_1) Operation

The operation of the Cuk converter in the DCVM (C_1) is described as follows. Fig. 6(a)–(c) shows the operation of the Cuk converter in three different intervals of a switching period and Fig. 6(d) shows the associated waveforms in a switching period.

Interval I: When switch S_w in turned ON as shown in Fig. 6(a), inductor L_i stores energy while capacitor C_1

discharges through switch S_w to transfer its energy to the dc-link capacitor C_d as shown in Fig. 6(d).

Interval II: The switch is in conduction state but intermediate capacitor C_1 is completely discharged; hence, the voltage across it becomes zero. Output inductor L_o continues to supply energy to the dc-link capacitor.

Interval III: As the switch S_w is turned OFF, input inductor L_i starts charging the intermediate capacitor, while the output inductor L_o continues to operate in continuous conduction and supplies energy to the dc-link capacitor.

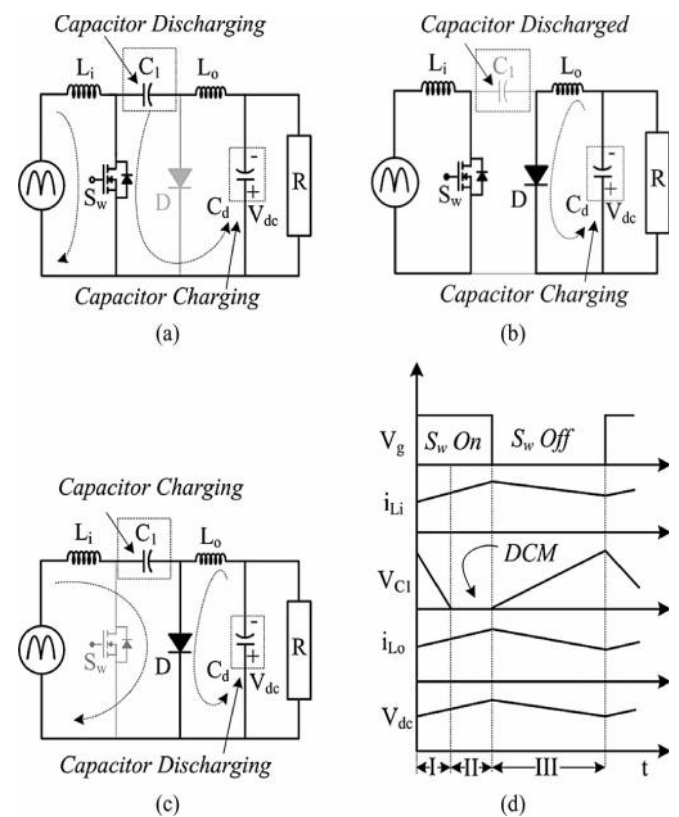

Fig. 6 Operation of the Cuk converter in the DCVM (C_1) during (a)–(c) different intervals of switching period and (d) associated waveforms (a) Interval I (b) Interval II (c) Interval III (d) Waveforms

IV. SIMULATED PERFORMANCE OF THE PROPOSED BLDC MOTOR DRIVE

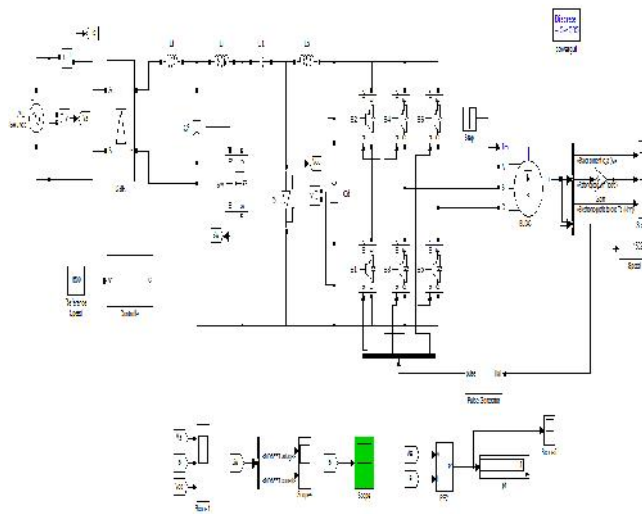

Fig 7 simulation diagram of proposed system

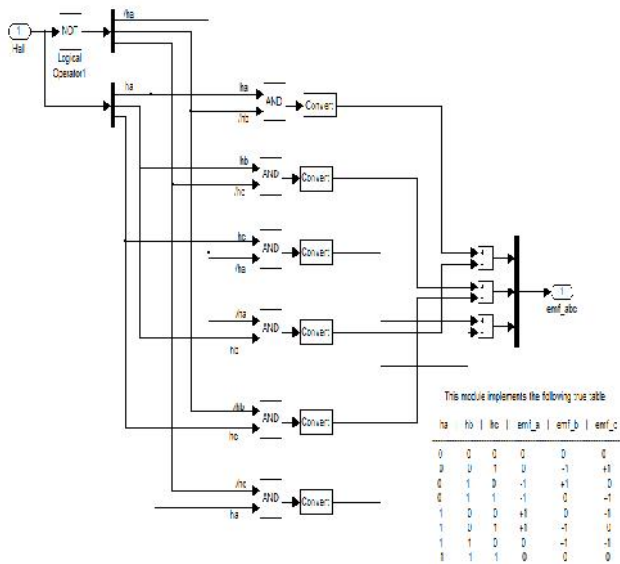

Fig 8 simulation diagram of hall signals to generate emf signals

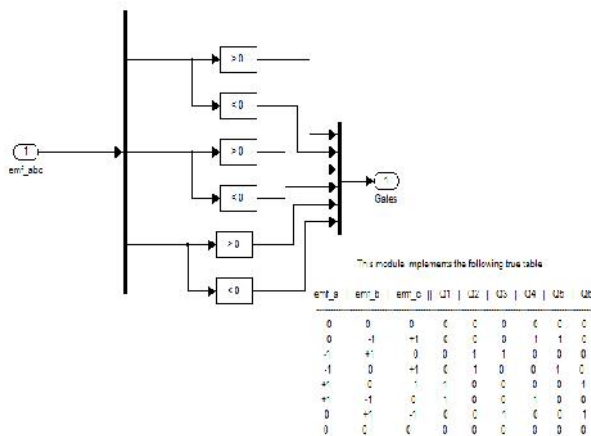

Fig 9 simulation diagram of emf signals to generate pulse signals

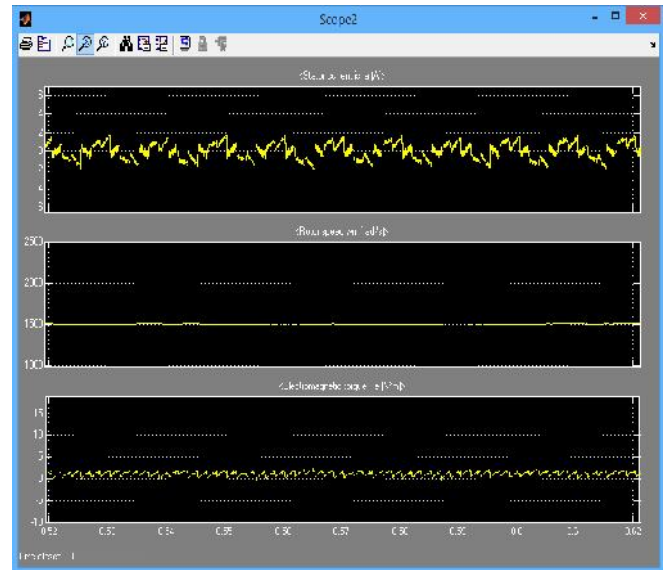

Fig 10 simulation results of stator current, rotor speed and electromagnetic torque

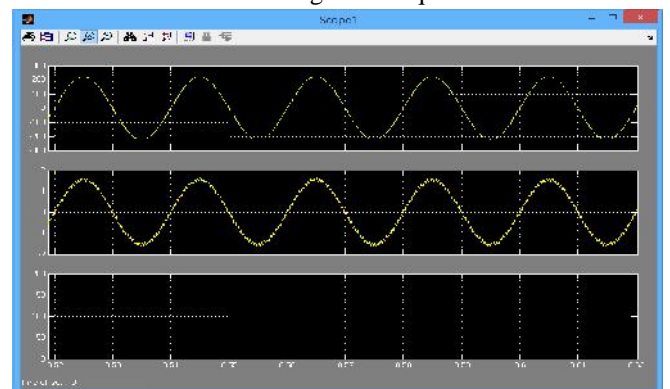

Fig 11 simulation results of voltage, current and Vdc

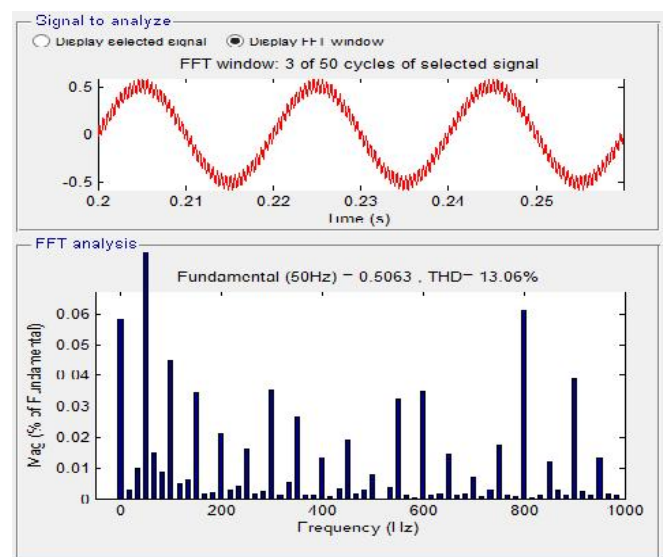

Fig 12. % THD for 500 rpm

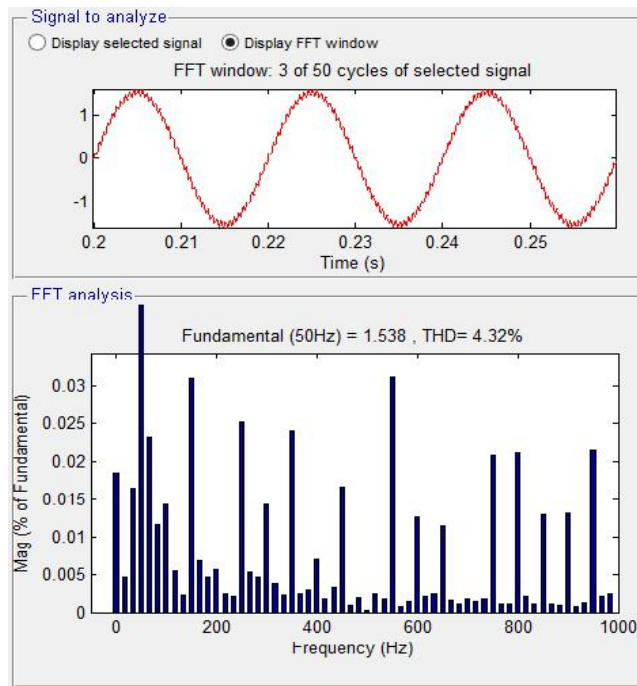

Fig 13. % THD for 1500 rpm

CONCLUSION

A DCM based PFC cuk converter-speed adjustable BLDC drive has been designed for achieving a unity PF at ac mains for the development of the low-cost PFC motor for numerous low-power equipments such fans, blowers, water pumps, etc. The speed of the BLDC motor drive has been controlled by varying the dc-link voltage of VSI, which allows the VSI to operate in the fundamental frequency switching mode for reduced switching losses. Four different modes of the Cuk converter operating in the CCM and DCM have been explored for the development of the BLDC motor drive with unity PF at ac mains.

A detailed comparison of all modes of operation has been presented on the basis of feasibility in design and the cost constraint in the development of such drive for low-power applications. Finally, a best suited mode of the Cuk converter with output inductor current operating in the DICM has been selected for experimental verifications. The proposed drive system has shown satisfactory results in all aspects and is a recommended solution for low-power BLDC motor drives.

REFERENCES

- [1] J. F. Gieras and M. Wing, *Permanent Magnet Motor Technology—Design and Application*. New York, NY, USA: Marcel Dekker, Inc, 2002.
- [2] C. L. Xia, *Permanent Magnet Brushless DC Motor Drives and Controls*. Beijing, China: Wiley, 2012.

- [3] Y. Chen, C. Chiu, Y. Jhang, Z. Tang, and R. Liang, "A driver for the singlephase brushlessDCfan motorwith hybrid winding structure," *IEEE Trans. Ind. Electron.*, vol. 60, no. 10, pp. 4369–4375, Oct. 2013.
- [4] S. Nikam, V. Rallabandi, and B. Fernandes, "A high torque density permanent magnet free motor for in-wheel electric vehicle application," *IEEE Trans. Ind. Appl.*, vol. 48, no. 6, pp. 2287–2295, Nov./Dec. 2012.
- [5] X. Huang, A. Goodman, C. Gerada, Y. Fang, and Q. Lu, "A single sided matrix converter drive for a brushlessDCmotor in aerospace applications," *IEEE Trans. Ind. Electron.*, vol. 59, no. 9, pp. 3542–3552, Sep. 2012.
- [6] W. Cui, Y. Gong, and M. H. Xu, "A permanent magnet brushless DC motor with bifilar winding for automotive engine cooling application," *IEEE Trans. Magn.*, vol. 48, no. 11, pp. 3348–3351, Nov. 2012.
- [7] C. C. Hwang, P. L. Li, C. T. Liu, and C. Chen, "Design and analysis of a brushless DC motor for applications in robotics," *IET Elect. Power Appl.*, vol. 6, no. 7, pp. 385–389, Aug. 2012.
- [8] T. K. A. Brekken, H. M. Hapke, C. Stillinger, and J. Prudell, "Machines and drives comparison for low-power renewable energy and oscillating applications," *IEEE Trans. Energy Convers.*, vol. 25, no. 4, pp. 1162–1170, Dec. 2010.
- [9] N. Milivojevic, M. Krishnamurthy, A. Emadi, and I. Stamenkovic, "Theory and implementation of a simple digital control strategy for brushless DC generators," *IEEE Trans. Power Electron.*, vol. 26, no. 11, pp. 3345– 3356, Nov. 2011.
- [10] T. Kenjo and S. Nagamori, *Permanent Magnet Brushless DC Motors*. Oxford, U.K.: Clarendon Press, 1985.
- [11] J. R. Handershot and T. J. E Miller, *Design of Brushless Permanent Magnet Motors*. Oxford, U.K.: Clarendon Press, 2010.
- [12] T. J. Sokira and W. Jaffe, *Brushless DCMotors: Electronics Commutation and Controls*. Blue Ridge Summit, PA, USA: Tab Books, 1989.
- [13] H. A. Toliyat and S. Campbell, *DSP-Based Electromechanical Motion Control*. New York, NY, USA: CRC Press, 2004.
- [14] "Limits for harmonic current emissions (equipment input current 16 A per phase)," International Standard IEC 61000-3-2, 2000
- [15] N. Mohan, T. M. Undeland, and W. P. Robbins, *Power Electronics: Converters, Applications and Design*. New York, NY, USA: Wiley, 2009.

- [16] B. Singh, B. N. Singh, A. Chandra, K. Al-Haddad, A. Pandey, and D. P. Kothari, "A review of single-phase improved power quality ACDC converters," *IEEE Trans. Ind. Electron.*, vol. 50, no. 5, pp. 962–981, Oct. 2003.
- [17] B. Singh, S. Singh, A. Chandra, and K. Al-Haddad, "Comprehensive study of single-phase AC-DC power factor corrected converters with high frequency isolation," *IEEE Trans. Ind. Inf.*, vol. 7, no. 4, pp. 540–556, Nov. 2011.
- [18] S. B. Ozturk, O. Yang, and H. A. Toliyat, "Power factor correction of direct torque controlled brushless DC motor drive," in *Proc. 42nd IEEE IAS Annu. Meeting*, Sep. 23–27, 2007, pp. 297–304.
- [19] T. Y. Ho, M. S. Chen, L. H. Yang, and W. L. Lin, "The design of a high power factor brushless DC motor drive," in *Proc. Int. Symp. Comput. Consum. Contr.*, Jun. 4–6, 2012, pp. 345–348.
- [20] C. H. Wu and Y. Y. Tzou, "Digital control strategy for efficiency optimization of a BLDC motor driver with VOPFC," in *Proc. IEEE Energy Convers. Congr. Expo.*, Sep. 20–24, 2009, pp. 2528–2534.
- [21] T. Gopalathnam and H. A. Toliyat, "A new topology for unipolar brushless DC motor drive with high power factor," *IEEE Trans. Power Electron.*, vol. 18, no. 6, pp. 1397–1404, Nov. 2003.
- [22] V. Bist and B. Singh, "An adjustable speed PFC bridgeless buck-boost converter fed BLDC motor drive," *IEEE Trans. Ind. Electron.*, vol. 61, no. 6, pp. 2665–2677, Jun. 2014.
- [23] B. Singh and V. Bist, "An improved power quality bridgeless Cuk converter fed BLDC motor drive for air conditioning system," *IET Power Electron.*, vol. 6, no. 5, pp. 902–913, 2013.
- [24] B. Singh and V. Bist, "Power quality improvement in PFC bridgeless SEPIC fed BLDC motor drive," *Int. J. Emerg. Elect. Power Syst.*, vol. 14, no. 3, pp. 285–296, 2013.
- [25] V. Bist and B. Singh, "A reduced sensor PFC BL-zeta converter based VSI fed BLDC motor drive," *Elect. Power Syst. Res.*, vol. 98, pp. 11–18, May 2013.
- [26] A. Ionovici, "A new computer-aided approach to the analysis of Cuk converter by using the alternator equations," *IEEE Trans. Power Electron.*, vol. 4, no. 3, pp. 319–330, Jul. 1989.
- [27] S. C. Wong and Y. S. Lee, "SPICE modeling and simulation of hysteretic current-controlled Cuk converter," *IEEE Trans. Power Electron.*, vol. 8, no. 4, pp. 580–587, Oct. 1993.
- [28] K. M. Smedley and S. Cuk, "Dynamics of one-cycle controlled Cuk converters," *IEEE Trans. Power Electron.*, vol. 10, no. 6, pp. 634–639, Nov. 1995.
- [29] L. Malesani, R. G. Spiazzi, and P. Tenti, "Performance optimization of Cuk converters by sliding-mode control," *IEEE Trans. Power Electron.*, vol. 10, no. 3, pp. 302–309, May 1995.
- [30] Z. Chen, "PI and sliding mode control of a Cuk converter," *IEEE Trans. Power Electron.*, vol. 27, no. 8, pp. 3695–3703, Aug. 2012.
- [31] M. Brkovic and S. Cuk, "Input current shaper using Cuk converter," in *Proc. 14th Int. Telecomm. Energy Conf.*, Oct. 4–8, 1992, pp. 532–539.
- [32] D. S. L. Simonetti, J. Sebastian, and J. Uceda, "The discontinuous conduction mode Sepic and Cuk power factor preregulators: Analysis and design," *IEEE Trans. Ind. Electron.*, vol. 44, no. 5, pp. 630–637, Oct. 1997.
- [33] S. Buso, G. Spiazzi, and D. Tagliavia, "Simplified control technique for high-power-factor flyback Cuk and Sepic rectifiers operating in CCM," *IEEE Trans. Ind. Appl.*, vol. 36, no. 5, pp. 1413–1418, Sep./Oct. 2000.
- [34] B. T. Lin and Y. S. Lee, "Power-factor correction using Cuk converters in discontinuous-capacitor-voltage mode operation," *IEEE Trans. Ind. Electron.*, vol. 44, no. 5, pp. 648–653, Oct. 1997.
- [35] V. Nasirian, Y. Karimi, A. Davoudi, and M. Zolghadri, "Dynamic model development and variable switching frequency control for DCVM Cuk converters in PFC applications," *IEEE Trans. Ind. Appl.*, vol. 49, no. 6, pp. 2636–2650, Nov./Dec. 2013.
- [36] V. Vlatkovic, D. Borzjevic, and F. C. Lee, "Input filter design for power factor correction circuits," *IEEE Trans. Power Electron.*, vol. 11, no. 1, pp. 199–205, Jan. 1996.
- [37] P. Alaeinovin and J. Jatskevich, "Filtering of hall-sensor signals for improved operation of brushless DC motors," *IEEE Trans. Energy Convers.*, vol. 27, no. 2, pp. 547–549, Jun. 2012.
- [38] H. Y. Kanaan and K. Al-Haddad, "A unified approach for the analysis of single-phase power factor correction converters," in *Proc. 37th Annu. Conf. IEEE Ind. Electron. Soc.*, Nov. 7–10, 2011, pp. 1167–1172.