



Power Quality Improvement in Utility Grid using Single Phase Micro Sources, DSTATCOM and Distributed Generators

Ajay Kumar P1, Sk Gouse Basha2, Ravi Kumar Reddy P3

1*Pursuing M.Tech in the field of POWER & INDUSTRIAL DRIVES

2*Working as, Assistant Professor in the EEE Department

3*Working as, Production In-charge in Transformers manufacturing Industry

ABSTRACT:

This paper proposes to improve the power quality in a utility connected grid by using converter based single phase micro sources. The voltage unbalance can be severe if single-phase rooftop mounted PVs are distributed randomly between the households. Moreover, there can also be single-phase nonlinear loads present in the system. The cumulative effect of all these will cause power quality problem at the utility side. To counteract this problem, we have proposed two different schemes. In this first scheme a distribution static compensator (DSTATCOM) is connected at the utility bus to improve the power quality. The DSTATCOM only supplies reactive power and no real power. In the second scheme, a larger three-phase converter controlled DG is placed that not only supplies the reactive power but also provides active power. The efficacies of the controllers have been validated through simulation for various operating conditions using MATLAB/SIMULINK.

I. INTRODUCTION:

More countries are aiming at a reduction in green- house gas emissions, the requirements for adding new generation capacity can no longer be met by traditional power generation methods of burning the primary fossil fuels such as coal, oil, natural gas, etc. This is why distributed generators (DG) have significant opportunity in the evolving power system network. Both consumers and power utilities can benefit from the widespread deployment of DG systems which offer secure and diversified energy options, increase generation and transmission efficiency, reduce greenhouse gas emissions, improve power quality and system stability, cut energy costs and capital expenditures, and alleviate the bottleneck caused by distribution lines.

Properly sited DG can increase the feeder capacity limit, but this does not necessarily produce an improvement in system reliability or power quality, as quantified by standard indices. With improving reliability of the owner, the DG may reduce the severity of voltage sags near the DG.

The DG often has a negative impact on reliability indices through sympathetic tripping, required changes to utility over current device settings, and increased fuse blowing. The utility cannot assume DG automatically improves system reliability, and action may be required to ensure that reliability does not actually degrade for other customers.

This paper proposes the operation and control of single phase micro-sources (DG) in a utility connected grid. While the DGs supply their maximum generated power, rest of the power demand of each phase is supplied by the utility and three phase DG connected at the PCC, if any. To counteract this problem, we have proposed two different schemes. In the first scheme, a distribution static compensator (DSTATCOM) is connected at the point of common coupling (PCC) to compensate the unbalance and nonlinear nature of the total load current and to provide the reactive power support. In the second scheme, a three phase DG, connected at the PCC, in place of the DSTATCOM to share both real and reactive power with the utility. The DG also compensates the system and makes the PCC voltage balanced.

The efficacies of the controllers and improvement in power quality have been validated through simulation for various operating conditions using PSCAD.

II. SYSTEM STRUCTURE:

The structure of the system studied in this paper is shown in Fig. 1. The utility is connected to the PCC through a primary feeder with an impedance of R_s, L_s . The supply side contains three single phase DGs and one three phases DG or DSTAT- COM. The single phases DGs are connected through secondary feeders to the PCC. The three phases DG or DSTACOM is also connected at the PCC. Since both these devices are used for improving power quality, they will be commonly called as the compensator. It is assumed that all the DG are inertia less and VSC-interfaced. Six single phase loads are denoted by Ld_1 to Ld_6 . The secondary feeder impedances are denoted by Z .

III. CONVERTER STRUCTURE & CONTROL:

The converter structure that is connected to the single-phase DGs is shown in Fig. 2. Here the DG is assumed to be an ideal dc voltage source supplying a voltage of V_{dc} to the VSC. The converter contains one H-bridges. The output of the H-bridge is connected to a single-phase transformer. The resistance R_f represents the switching and transformer losses, while the inductance L_f represents the leakage reactance of the transformers. The filter capacitor C_f is connected to the output of the transformers to bypass switching harmonics. The inductance L_G is physically connected to represent the output inductance of the converter-DG source combination. The same converter structure is used for all the single phase DG sources. The three phase compensator contains three such H-bridges. However, it is connected to the PCC without any output inductance. The schematic diagram is shown in Fig. 3. It is to be noted that for a DSTACOM, the dc bus contains a dc capacitor, while for a DG-compensator; the dc bus is supplied by an ideal voltage source.

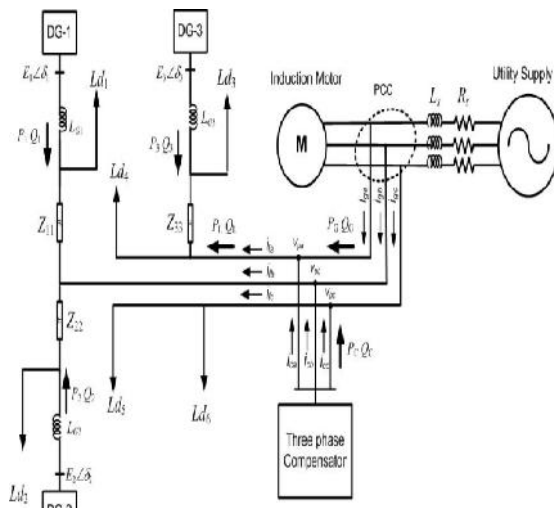

Fig.1: Structure of the grid system under consideration

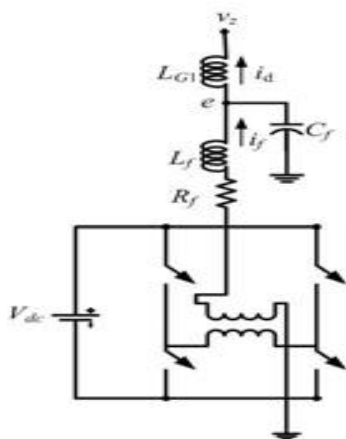

Fig.2: Single-phase converter structure

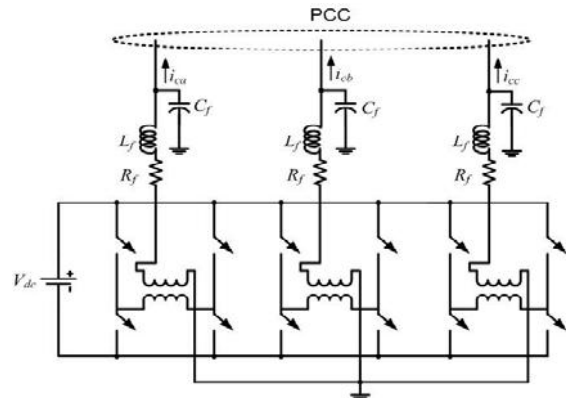

Fig.3: Three-phase converter structure for the compensator

A. Control of Single-Phase VSCs:

The single-phase VSCs are controlled under closed-loop feedback. Consider the equivalent circuit of one phase of the converter as shown in Fig. 4. In this, $u \cdot V_{dc}$ represents the converter output voltage, where u is the switching function that can take on values ± 1 . The main aim of the converter control is to generate u . From the circuit of Fig. 4, the state space description of the system can be given as

$$\dot{x} = Ax + B1uc + B2vPCC \tag{1}$$

where uc is the continuous time control input, based on which the switching function u is determined. The discrete-time equivalent of (1) is

$$x(k+1) = Fx(k) + G1uc(k) + G2vPCC(k) \tag{2}$$

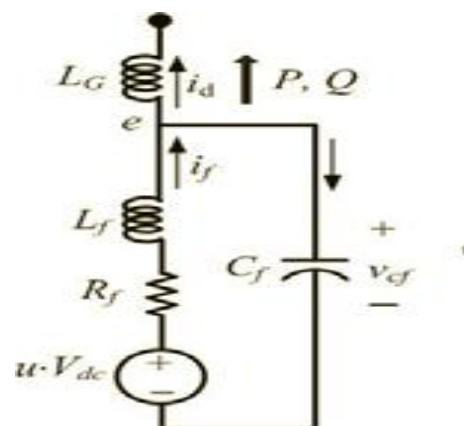

Neglecting the PCC voltage v_{PCC} assuming it to be a disturbance input, the input-output relationship of the system in (2) can be written in the following two forms

$$\frac{v_{cf}(z)}{u_c(z)} = \frac{M_1(z^{-1})}{N(z^{-1})} \quad (3)$$

$$\frac{\hat{i}_1(z)}{u_c(z)} = \frac{M_2(z^{-1})}{N(z^{-1})} \quad (4)$$

The feedback control laws of the converters are generated as discussed below. The single phase DGs are controlled in a sinusoidal current limiting mode. In this mode, the output current is required to produce the maximum available power. Let the current reference for the maximum available power be denoted as i_l^* . This is then tracked using a pole placement method to compute $u_c(k)$ from (4).

B. Feedback Control of the Compensator:

In the three phase compensator structure shown in Fig. 3, each of the H-bridges are controlled in state feedback. For this, a state vector can be defined as

$$\mathbf{x}^T = [v_{cf} \ i_{cf} \ i_1]$$

The state feedback control law is

$$u_c(k) = K[x^*(k) - x(k)] \quad (5)$$

Where K is the feedback gain matrix and x^* is the reference state vector. In this paper, this gain matrix is obtained using LQR method. How the references are set for either of the controller will be discussed in the next section.

C. Switching Control:

Once $u_c(k)$ is computed from either state feedback or output feedback, the switching function u is generated from,

$$\begin{aligned} \text{If } u_c > h \text{ then } u &= +1 \\ \text{elseif } u_c < -h \text{ then } u &= -1 \\ \text{where } h \text{ is a small number.} \end{aligned} \quad (6)$$

IV. REFERENCE GENERATION:

As mentioned in the previous section, the VSCs connoted to the single phase DGs are controlled in the current feedback mode while in the three-phase compensator is controlled in the state feedback mode. The reference generation for these two different control modes is discussed in this section.

A. Current Feedback:

As discussed in the previous section when the power output of the DG suddenly reduces or the load demands more than the rated output power from the DG, it is switched to a sinusoidal current limiting mode. Let the maximum available power rating of the DG be denoted by P_{rated} and Q_{rated} . The magnitude

and angle of the reference current is calculated from the voltage magnitude (V_z , See Fig. 2) of the adjacent bus voltage as

$$\begin{aligned} I_1 &= \sqrt{P_{rated}^2 + Q_{rated}^2} / V_z \\ \beta &= \delta_z - \tan^{-1}(Q_{rated} / P_{rated}) \end{aligned} \quad (7)$$

Where δ_z is the angle of the bus voltage (V_z). The instantaneous quantities are then generated from these phasor quantities.

B. Three Phase DG-Compensator Reference Generation:

The main aim of the compensator is to cancel the effects of unbalanced and harmonic components of the load. If proper compensation is achieved, the currents i_g and i_2 will be balanced and so will be the voltage v_p provided that v_s is balanced. In addition, the DG-compensator can also supply a part of the real and reactive power required, while the DSTATCOM only supplies reactive power. In this subsection, we shall first present the generalized reference generation scheme for the DG-compensator. This will then be modified for the DSTATCOM scheme in the next sub-section. Let us denote the three phases by the subscripts a , b and c . Consider the circuit of Fig. 1 in which the current entering the distribution system from PCC is denoted by i_g and the current supplied to the distribution system is denoted by i_l . The compensator current is denoted by i_c such that the Kirchoff's current law (KCL) at the compensator coupling point is given by

$$i_{ck} + i_{gk} = i_{lk}, \quad k = a, b, c \quad (8)$$

Since it is desired that the supplied currents are balanced, we have

$$i_{ga} + i_{gb} + i_{gc} = 0 \quad (9)$$

Therefore combining (8) and (9) by adding the currents of the all the three phases together, we get

$$i_{ca} + i_{cb} + i_{cc} = i_{la} + i_{lb} + i_{lc} \quad (10)$$

Since i_g is balanced due to the action of the compensator, the voltage v_p will also become balanced provided that the supply voltage is balanced. Hence the instantaneous real powers P_G will be equal to its average components. Therefore we can write

$$v_{pa}i_{ga} + v_{pb}i_{gb} + v_{pc}i_{gc} = P_G \quad (11)$$

From the KCL of (8), (11) can be written as,

$$v_{pa}(i_{la} - i_{ca}) + v_{pb}(i_{lb} - i_{cb}) + v_{pc}(i_{lc} - i_{cc}) = P_G \quad (12)$$

Similarly the reactive powers Q_G and Q_C will be equal to their instantaneous components. Therefore we can write

$$(v_{pb} - v_{pc})i_{ga} + (v_{pc} - v_{pa})i_{gb} + (v_{pa} - v_{pb})i_{gc} = \sqrt{3} \times Q_G \quad (13)$$

Using the KCL of (8), (13) can be rewritten as

$$(v_{pb} - v_{pc})(i_{ia} - i_{ca}) + (v_{pc} - v_{pa})(i_{ib} - i_{cb}) + (v_{pa} - v_{pb})(i_{ic} - i_{cc}) = \sqrt{3}Q_G \quad (14)$$

Equations (10), (12) and (14) form the basis of the algorithm. From these three, the following can be written

$$A \begin{bmatrix} i_{ca} \\ i_{cb} \\ i_{cc} \end{bmatrix} = A \begin{bmatrix} i_{ia} \\ i_{ib} \\ i_{ic} \end{bmatrix} + \begin{bmatrix} 0 \\ -P_G \\ -\sqrt{3}Q_G \end{bmatrix} \quad (15)$$

where

$$A = \begin{bmatrix} 1 & 1 & 1 \\ v_{pa} & v_{pb} & v_{pc} \\ v_{pb} - v_{pc} & v_{pc} - v_{pa} & v_{pa} - v_{pb} \end{bmatrix}$$

The determinant of the matrix A is given by

$$|A| = v_{pa}(v_{pc} + v_{pb} - 2v_{pa}) + v_{pb}(v_{pc} + v_{pa} - 2v_{pb}) + v_{pc}(v_{pb} + v_{pa} - 2v_{pc}) \quad (16)$$

If v_p is balanced, then the following is true

$$v_{pa} + v_{pb} + v_{pc} = 0 \quad (17)$$

Substituting (17) in (16), the determinant of A is given as

$$|A| = -3(v_{pa}^2 + v_{pb}^2 + v_{pc}^2) \quad (18)$$

Computing the inverse of the matrix A , the solution of (15) is given as

$$\begin{bmatrix} i_{ca} \\ i_{cb} \\ i_{cc} \end{bmatrix} = \begin{bmatrix} i_{ia} \\ i_{ib} \\ i_{ic} \end{bmatrix} + \frac{1}{|A|} \begin{bmatrix} 3P_G v_{pa} + \sqrt{3}Q_G(v_{pb} - v_{pc}) \\ 3P_G v_{pb} + \sqrt{3}Q_G(v_{pc} - v_{pa}) \\ 3P_G v_{pc} + \sqrt{3}Q_G(v_{pa} - v_{pb}) \end{bmatrix} \quad (19)$$

Now let us stipulate that the utility supplies PG that is λ_p times the average power $PLav$ supplied to the distribution system and Q_G which is λ_q times the average reactive power $QLav$ supplied to the distribution system. This is given by the following two relations

$$\begin{aligned} P_G &= \lambda_p \times P_{Lav} \\ Q_G &= \lambda_q \times Q_{Lav} \end{aligned} \quad (20)$$

Substituting (20), in (19), the reference currents are given by

$$\begin{bmatrix} i_{ca} \\ i_{cb} \\ i_{cc} \end{bmatrix} = \begin{bmatrix} i_{ia} \\ i_{ib} \\ i_{ic} \end{bmatrix} + \frac{1}{|A|} \begin{bmatrix} 3\lambda_p P_{Lav} v_{pa} + \sqrt{3}\lambda_q Q_{Lav}(v_{pb} - v_{pc}) \\ 3\lambda_p P_{Lav} v_{pb} + \sqrt{3}\lambda_q Q_{Lav}(v_{pc} - v_{pa}) \\ 3\lambda_p P_{Lav} v_{pc} + \sqrt{3}\lambda_q Q_{Lav}(v_{pa} - v_{pb}) \end{bmatrix} \quad (21)$$

For the state feedback control of (5), we not only need the reference currents of (21), but also the reference for the voltages v_{pk} , $k = a, b, c$ and the currents through the filter capacitors C_f (see Fig. 3). The reference for the voltage v_p is set by extracting the fundamental positive sequence of the voltage measurements at this point, while the capacitor current is the derivative of this voltage multiplied by the capacitance value C_f .

C. Three Phase DSTATCOM Reference Generation:

Since a DSTATCOM is supplied by a dc capacitor, it can only supply a part of the reactive power and no real power. Therefore the entire real power must come from the utility and hence in (20), the coefficient λ_p should be equal to 1. The coefficient λ_q should be chosen based on the ratio of what portion of the reactive power should be supplied by the DSTATCOM. Therefore the reference currents for this case are given by modifying (21) as

$$\begin{bmatrix} i_{ca} \\ i_{cb} \\ i_{cc} \end{bmatrix} = \begin{bmatrix} i_{ia} \\ i_{ib} \\ i_{ic} \end{bmatrix} + \frac{1}{|A|} \begin{bmatrix} 3P_{Lav} v_{pa} + \sqrt{3}\lambda_q Q_{Lav}(v_{pb} - v_{pc}) \\ 3P_{Lav} v_{pb} + \sqrt{3}\lambda_q Q_{Lav}(v_{pc} - v_{pa}) \\ 3P_{Lav} v_{pc} + \sqrt{3}\lambda_q Q_{Lav}(v_{pa} - v_{pb}) \end{bmatrix} \quad (22)$$

Once the reference currents are obtained, the references of the voltage v_p and filter capacitor currents are obtained in the same manner as discussed in the previous sub-section.

V. SIMULATION STUDIES:

Simulation studies are carried out in PSCAD/EMTDC (version 4.2). The DGs are considered as inertia-less dc sources supplied through the VSCs.

A. Case-1: Without Compensator:

It is assumed that all the single phase DGs are able to supply their maximum rated power. As is evident from Table-I that the total load demand is more than the total maximum generation. Thus the rest of the power requirement has to be supplied from the utility. It is assume that the system is operating in the steady state in which DG-2 is supplying 3 kW and load $Ld1$ is not connected. Suddenly at 0.45 s, the power output of DG-2 increase to 7 kW. Furthermore, at 0.7 s, the load $Ld1$ gets connected drawing real and

reactive power of 4.2 kW and 3.2 kVAr respectively. The system response is shown in Fig. 5. It can be seen that the maximum power supply by DG-2 increase, while the load change has not impact on the maximum power supplied by any of the DGs.

Fig. 6 (a) shows the power supplied by the utility. The oscillation in the power is due to the imbalance in the three phases. At 0.45 s the utility power decreases as the power generation in DG-2 is increased, while at 0.7 s the utility supply is increased to supply the load change in phase b. Fig. 6 (b) shows the unbalanced utility currents in the three phases.

(a) Active power supply of single phase DG's



(b) Reactive power supply of single phase DG's

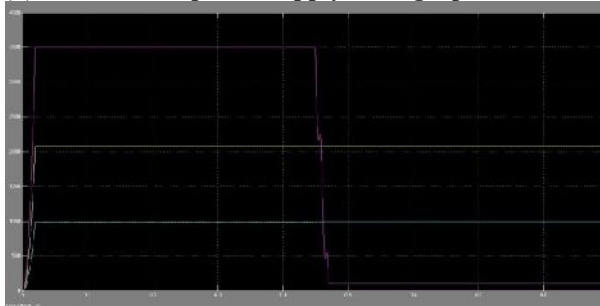
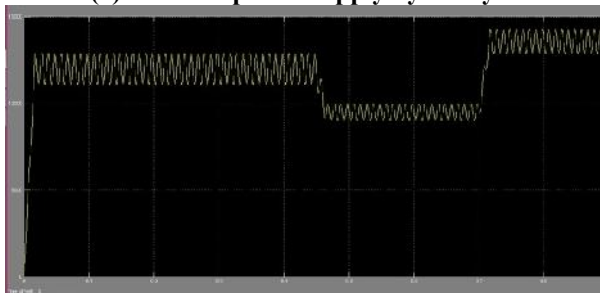

Fig.5 :. Real and reactive power sharing for Case-1

(a) Real power supply by utility



(b) Three phase current from utility

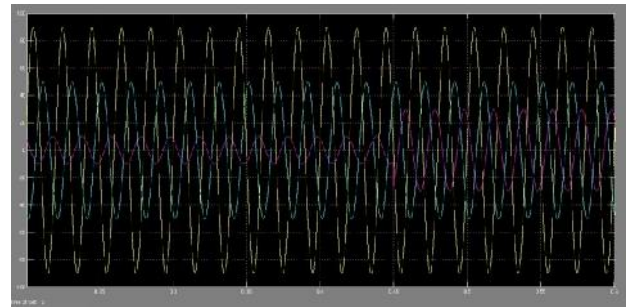
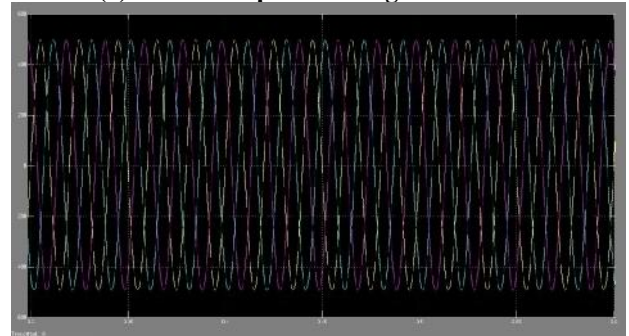

Fig.6: Real power and three phase current from utility

Let now investigate the impact of unbalanced currents on the induction motor that is connected at the PCC (see Fig. 1) for the same test as in Figs. 5 and 6. Fig. 7 (a) shows the three phase PCC voltage while Fig. 7 (b) shows the electrical torque of the induction machine. The unbalanced voltage at PCC creates the torque pulsation. High torque pulsation is totally undesirable for the operation of the induction motor.

(a) Three phase voltage at PCC



(b) Induction motor electrical torque

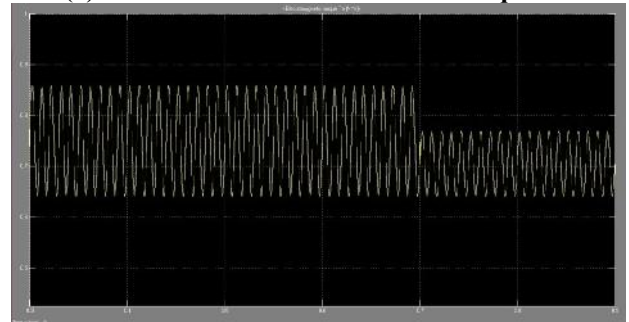

Fig.7: Voltage at PCC and induction motor torque

B Case-2: DSTATCOM Connected at PCC:

To compensate the imbalance among the phases, at first a DSTATCOM is connected as a three phase compensator. As discussed previously, DSTATCOM can share the reactive power requirement with utility in a pre-specified ratio. With the initial starting condition as in Case-1, the

DSTATCOM is connected to the system at 0.2 s and it is desired that DSTATCOM supply the 70% of the reactive power while balancing the utility currents. The system responses are shown from Figs. 8-10. Fig. 8 shows the utility and DSTATCOM current. It can be seen that the utility currents gets balanced after the DSTATCOM connection. However, the DSTATCOM supplies unbalanced currents to compensate for the downstream unbalance.

(a) Three phase current from utility

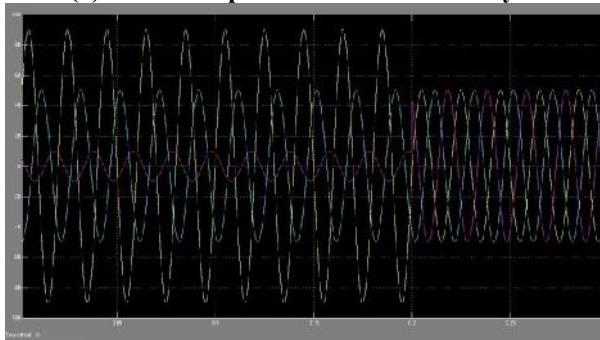

(b) Three phase compensator current

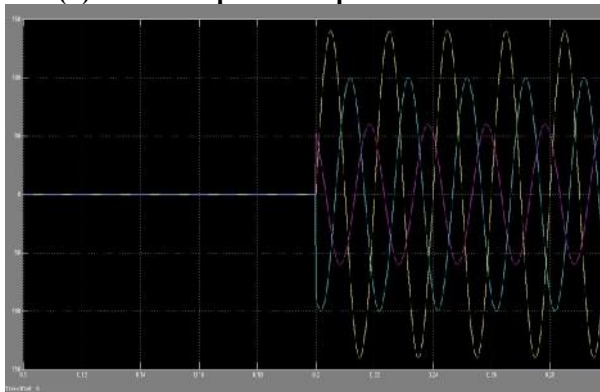

Fig.8: Three-phase currents from utility and DSTATCOM

The reactive power sharing between QG , QC and QL is shown in Fig. 9. It can be seen that the DSTATCOM and the utility share the reactive power in 7:3 ratio as desired. Also, the DSTATCOM reactive power oscillates in sympathy with QL , while QG becomes flat.

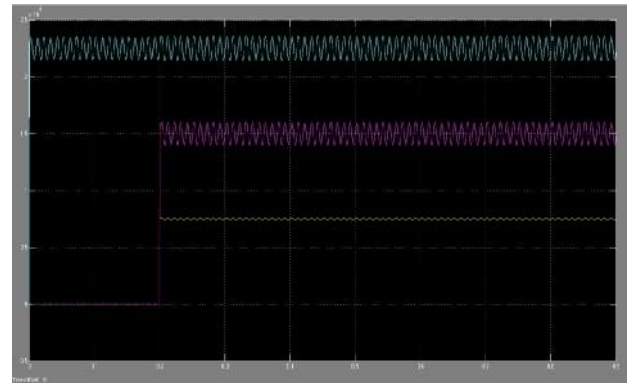
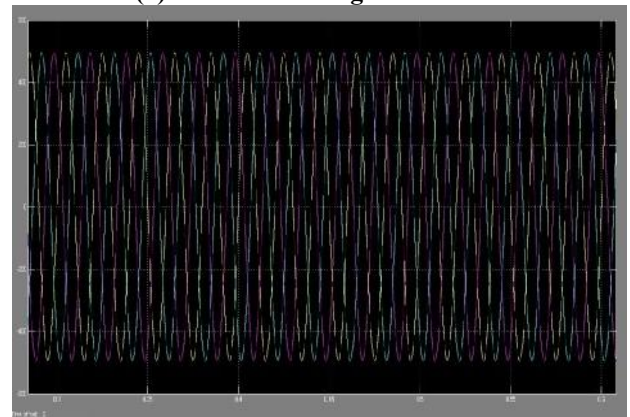

Fig.9: Reactive power sharing with DSTATCOM

The three-phase PCC voltages are shown in Fig. 10 (a) the induction motor torque is shown in Fig. 10 (b). The PCC voltages become balanced within 3-4 cycle after the DSTATCOM is connected to the system and the motor torque pulsation disappears and it becomes constant.

(a) Three voltage at PCC



(b) Electrical torque of induction motor



Fig.10: Voltage at PCC and induction motor torque

C. Case-3: DG-Compensator Connected at PCC:

While the DSTATCOM can only provide the required reactive power, a compensator connected with DG can also share the real power burden of the

utility. Let us assume that the DG-compensator supplies 30% of the real and reactive power demand (PL , QL), when it gets connected to the system at 0.45 s. The system responses are shown in Figs.11-13. Fig. 11 shows the three phase current from utility and DG compensator. The real and reactive power sharing are shown in Fig. 12. While utility provides balanced real and reactive power, the DG supplies the oscillating component alone in the desired ratio. The three-phase PCC voltages and the induction motor torque are shown in Fig. 13.

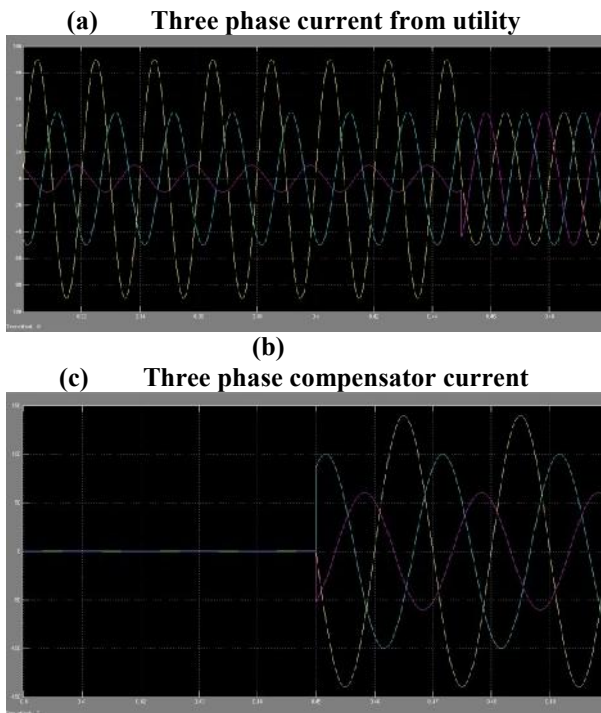

Fig.11: Three phase current from utility and DG-compensator

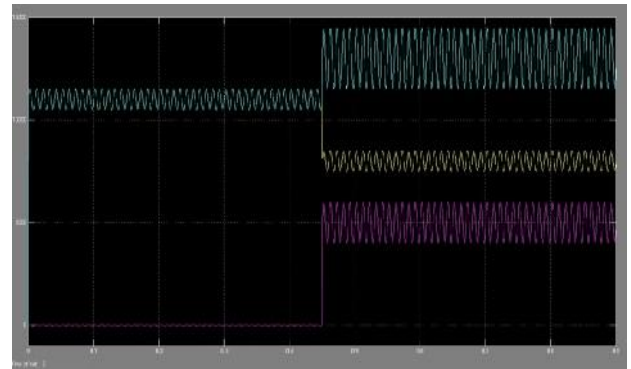
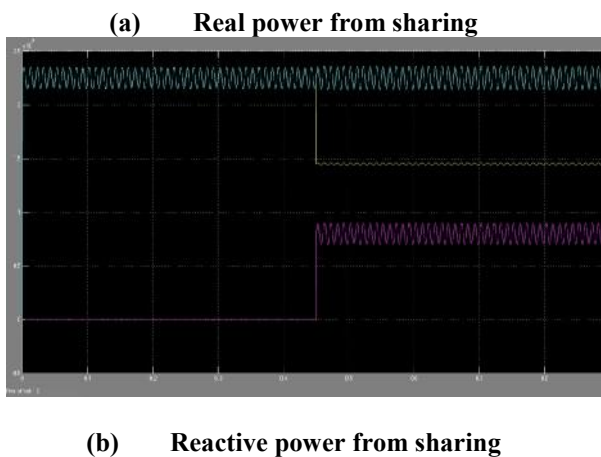

Fig.12: Real and reactive power from utility and DG-compensator.

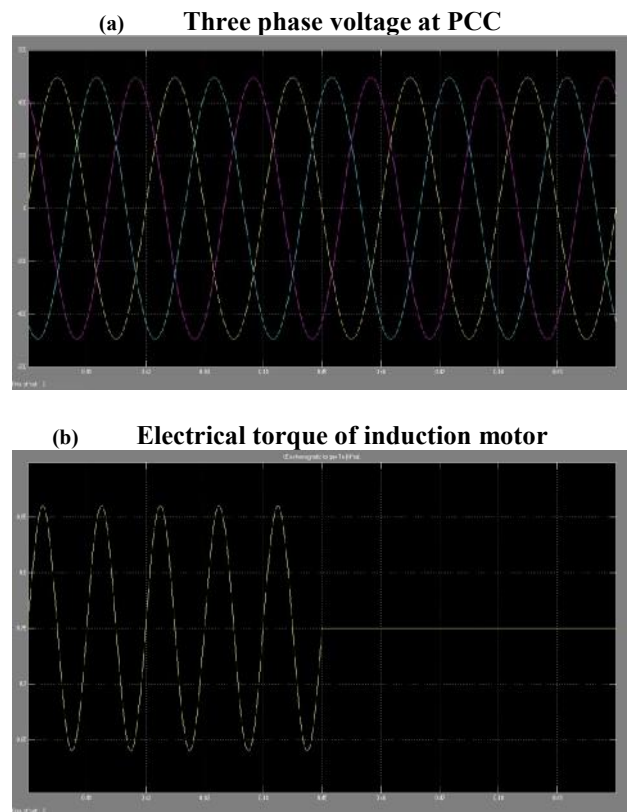

Fig.13: Voltage at PCC and induction motor torque

Nonlinear Loads:

To investigate the efficacy of the DG-compensator further, nonlinear loads are added to the linear loads $Ld1$, $Ld4$ and $Ld5$. It is assumed that the power consumed by these nonlinear loads is 20% of their linear counterparts. The results are shown in Fig. 14 where is DG-compensator is connected at 0.45 s. It can be seen from Fig. 14 (a) that the utility currents get balanced as soon as the DG-compensator is connected. The induction motor torque pulsation also ceases due to the DG-compensator connection as can be seen from Fig. 14 (b). The total harmonic distortion

(THD) has been computed for this case. The THD of the grid voltage is about 10 % and the negative and zero sequence components are around 5 % of the positive sequence component before DG-compensation connection. These are then reduced such that the THD becomes less than 0.5 %, whereas, negative and zero sequence components of the voltages remain below 0.02 % once the DG compensator is connected.

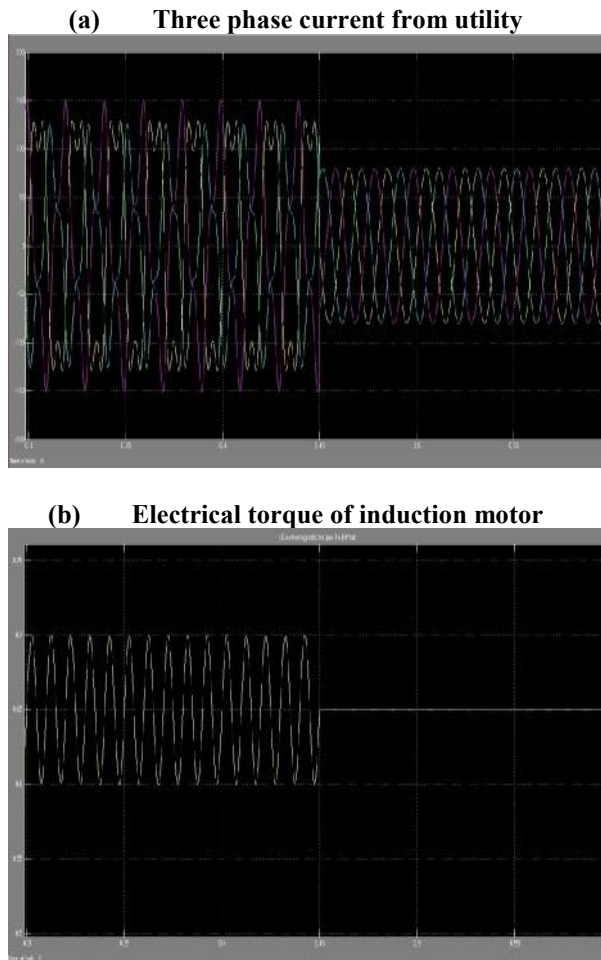

Fig.14: System response with non-linear loads

VI. CONCLUSIONS:

In this paper, the operation and control of single phase DG sources are considered in a three-phase utility connected grid. The single phase sources are operated to deliver available maximum power generated while the rest of the power demands in each of the phases are supplied by utility (and if available, three phase DG sources). The imbalance in three phase power is compensated two ways –either through a DSTATCOM or through a DG-compensator. A DSTATCOM can compensate for unbalances and

nonlinearities, while providing reactive power support. The size of the dc capacitor determines how much reactive power support the DSTATCOM can provide without any drop in voltage. The choice of this capacitor is thus a trade-off between the reactive support and system response [6].

Alternatively a three phase DG-compensator can be connected at the PCC to share the real and reactive power with utility and to compensate for the unbalance and nonlinearities in the system. The efficacy of the compensation is validated through extensive simulations and calculation of THD. With the proposed structure of distribution system, it is possible to operate single phase DG sources in a utility connected grid and this might become a useful tool as their penetration in distribution systems increases.

VII REFERENCES:

- [1] B. K. Bose, "Energy, environment, and advances in power electronics," IEEE Trans. on Power Electronics, vol. 15, pp. 688–701, July 2000.
- [2] X. Yoasuo, C. Liuchen, B. K. Soren, B. Josep and S. Toshihisa, "Topologies of single-phase inverters for small distributed power generators: an overview", IEEE Trans. on Power Electronics, vol. 19, pp. 1305-1314, Sep 2004
- [3] T. E. McDermott, R. C. Dugan, "Distributed generation impact on reliability and power quality indices" Rural Electric Power Conference, 2002, pp D3-D3_7.
- [4] Y. W. Li, D. M. Vilathgamuwa and P. C. Loh, "A grid-interfacing power quality compensator for three-phase three-wire microgrid applications," IEEE Trans on Power Electronics, Vol. 21, Issue 4, pp. 1021- 1031, July 2006
- [5] A. Ghosh, A. K. Jindal and A. Joshi, "Inverter control using output feedback for power compensating devices," Proc. IEEE Asia-Pacific Region-10 Conference TENCON, Bangalore, pp. 49-52, October 2003.
- [6] A. Ghosh and G. Ledwich, "Load compensating DSTATCOM is weak ac systems," IEEE Trans. Power Delivery, Vol. 18, No. 4, pp. 1302- 1309, 2003.
- [7] W. Freitas, A. Morelato, X. Wilsun and F. Sato, "Impacts of ac generators and DSTATCOM devices on the dynamic performance of distribution systems," IEEE Trans. On Power Delivery, Vol. 20, No. 2, pp. 1493-1501, 2005.

AUTHOR PROFILE:

1*AJAY KUMAR P Pursuing M.Tech in Nimra College of Engineering and Technology, Vijayawada .His specialization is Power & Industrial Drives. He graduated in Electrical and Electronics Engineering

from JNTU KAKINADA. His research interest includes Power flow control using converters, Power Electronic Converters and applications.
(sraghavajay@gmail.com)

2*SK GOUSE BASHA is currently working as a Assistant Professor in Electrical and Electronics Engineering Department, Nimra College of Engineering and Technology (NCET), Vijayawada. He obtained his M.Tech Degree from JNTU University. He received B.Tech degree in Electrical and Electronics Engineering from NCET, Vijayawada. His research interest includes Power Electronic Converters and applications.

3*P.RAVIKUMAR REDDY is currently working as a Production In-charge in transformers manufacturing industry in Kadapa, AP, INDIA. He graduated in Electrical and Electronics Engineering from JNTU Anantapur. He obtained his M.Tech Degree from JNTU Kakinada. His research interest includes Power quality control, Power Electronic Converters & applications and Electrical machines.
(reddy.ravi207@gmail.com)